

QSeal Connectors Customer Assembly Instructions

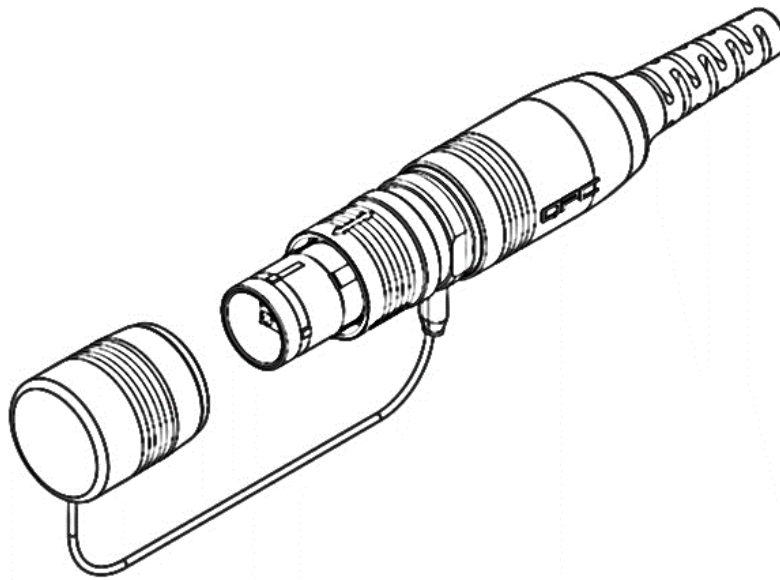

Document: CAI-QSEAL
Release Date: 11/15/2021

Revision: 0
Revision Date: N/A



SCOPE

This document describes the Assembly Instructions for the QSeal Product Line. Please use the Configuration Table below to locate the applicable section(s) based on the products needing assembly.

CONFIGURATION TABLE

Plugs	Page	Receptacles	Page
2 Channel Configuration – Cable OD Range: 3.6mm to 6.5mm	3	N/A	N/A
2 Channel Configuration – Cable OD Range: 6.6mm to 10.5mm	4		
4 Channel Configuration – Cable OD Range: 3.6mm to 6.5mm	9		
4 Channel Configuration – Cable OD Range: 6.6mm to 10.5mm	12		

SAFETY

Please use caution when following these instructions. This is not an exhaustive list of safety guidelines, refer to local regulations and your own company’s policies. For more information, please refer to QPC Fiber Optic General Fiber Handling Instructions (CAI-GEN).

- Be careful when handling bare fibers as sharp ends may penetrate skin.
- Wear appropriate personal protective equipment such as gloves and safety glasses.
- Track all fiber scraps and dispose of properly. Tape may be used to remove scraps from the worktable.
- Wash hands after handling fiber and before touching eyes or face.
- Do not look down fiber ends unless certain there is no light source coming through the fiber.
- Keep all combustible materials safely away from curing ovens.

STANDARD & SPECIALTY ASSEMBLY TOOLS

Refer to QPC CAI-TOOLS for a list of Standard & Specialty Assembly Tools used in this instruction.

TORQUE TABLE

Refer to the Torque Table below for the torque values for various components used in this instruction.

Component		Backshell	Strain Relief	Socket Head Cap Screw	Set Screws
Torque Values / Units	In-lb	57 – 62	26 – 35	3 – 4	2.25 – 2.75
	N • m	6.5 – 7.0	3.0 – 4.0	.34 – .45	0.25 – 0.31

PLUG, 2 CHANNEL CONFIGURATION – Cable OD Range: 3.6mm to 6.5mm

CABLE PREPARATION

Slide parts onto cable in the order below.

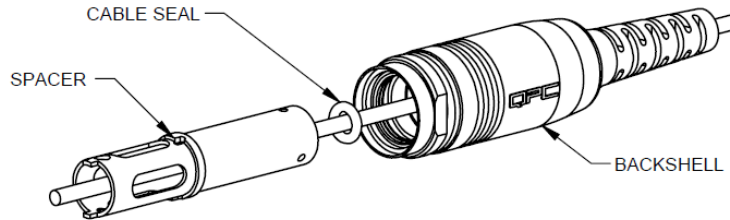

Strip cable jacket approximately 6" (152 mm) from end and place Crimp Support over fiber and Kevlar. Bend Kevlar back over the Crimp Support. Slide Crimp over Kevlar and Crimp Support to prepare for crimping.



Setup the Hydraulic Crimping tool PT-540 with the Die Set PT-541. The Crimp Die with Stop needs to be placed on the bottom facing out and with the Crimp against the stop as seen in the image below. Turn the knob clockwise on the Hydraulic Crimper, so that the handles can be pumped to crimp. Place the cable in the lower Crimp Die with the fiber facing out. Pump the handles until the Crimp Dies are touching. Release crimp by turning knob counterclockwise.

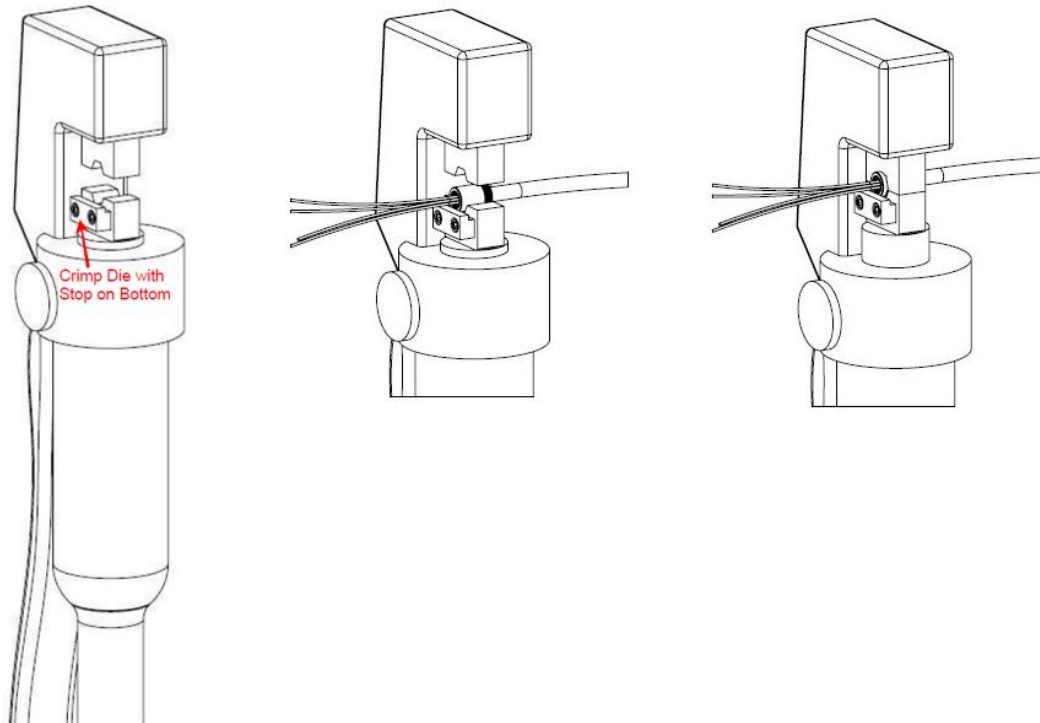

TERMINATION

Use the Stripping Length Diagrams located in the Appendix with the Fiber Optic Termination and Polishing Assembly Instructions (reference CAI-TERM) to terminate each fiber.

POPULATE INSERT

Slide the Fiber Optic Termini into the Insert Cap according to the desired pinout. Assemble Insert Body to the back of the Insert Cap ensuring that the 900µm fiber slide into the side slots of the Insert Body to prevent pinching during assembly. Apply Loctite 243 on the Socket Head Cap Screw threads per manufacturer’s instructions or equivalent may be used and screw the Insert using Hex Driver PT-503 and Torque Driver PT-590 with Hex Bit 5/64” PT-599 to torque the Socket Head Cap Screws to the values in the above Torque Table.

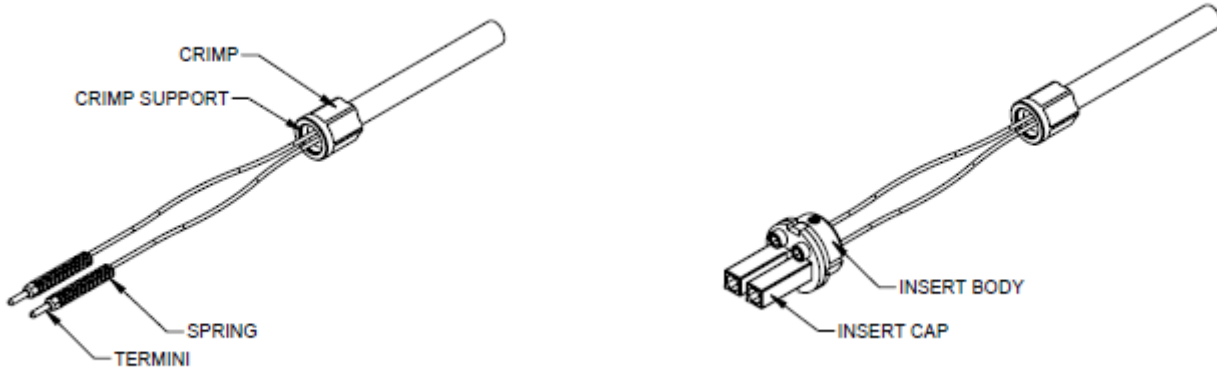

CONNECTOR ASSEMBLY

Slide the Spacer up and screw in the Flat Head Screws to the Insert Body using a Philips Screwdriver.

Pull Crimp to bottom of Spacer, apply Loctite on the Set Screw threads and tighten using Hex Driver PT-500. Use Torque Hex Driver PT-590 with Hex Bit .050” PT-599 and torque to the values in the above Torque Table.

Perform a visual check by looking through the holes in the Spacer to make sure that the fiber is not twisted or kinked.

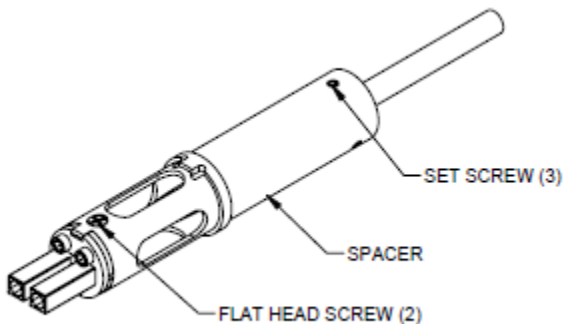

CAI-QSEAL: QSeal Customer Assembly Instructions

Place the Insert end into the Body Assembly. The keys on the Spacer should engage with the keyways in the Body Assembly. Slide the Backshell into position and tighten by hand onto the Body Assembly making sure that the Spacer does not turn relative to the Body. Insert the Plug Assembly onto the 2 Channel part of the Torque Fixture Stand PT-317.

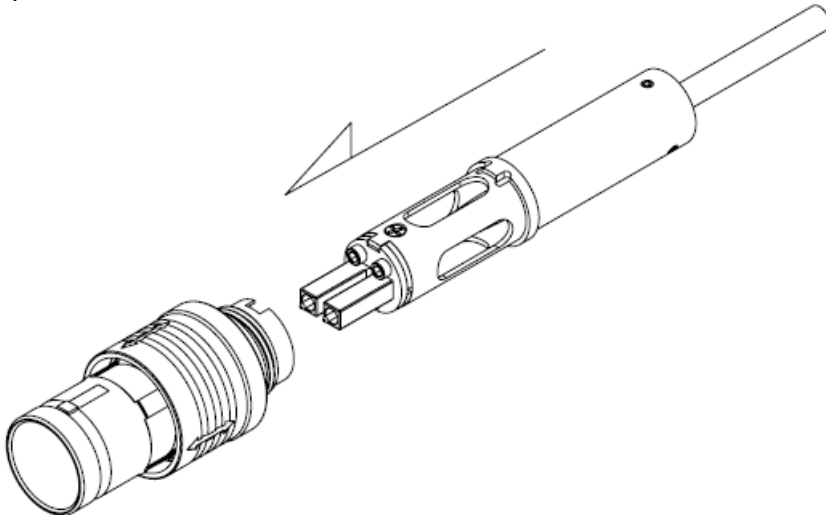

Slide the Backshell into position and tighten by hand onto the Body Assembly making sure that the Insert does not turn relative to the Body. Insert the Plug Assembly into the 4 Channel part of the Torque Fixture Stand PT-317. Torque the Backshell using Dial Torque-Measuring Wrench PT-506 with Crow's Foot Wrench PT-536 to the values in the above Torque Table. Make sure not to over torque the Backshell as this will cause damage.

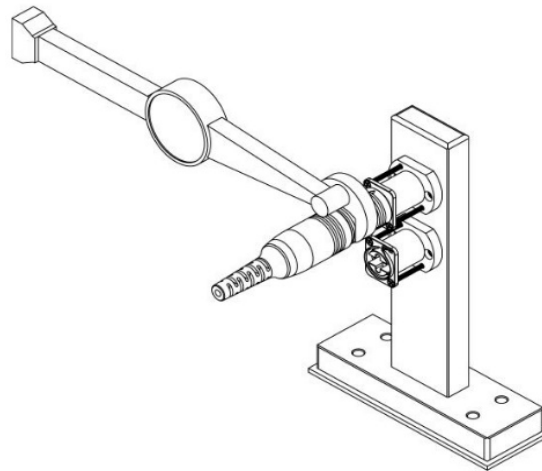
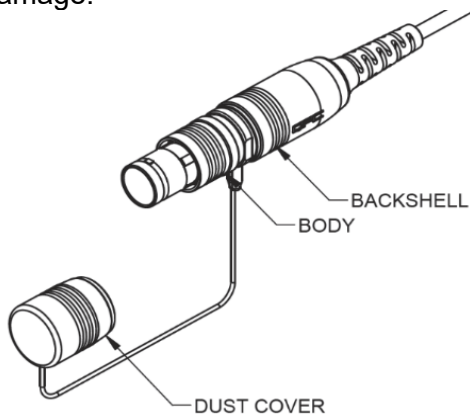

NOTE: After torquing, ensure that the insert is clocked properly in the Body with respect to the main key.

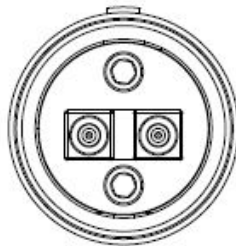

PLUG, 2 CHANNEL CONFIGURATION – Cable OD Range: 6.6mm to 10.5mm

CABLE PREPARATION

Slide parts onto cable in the order below.

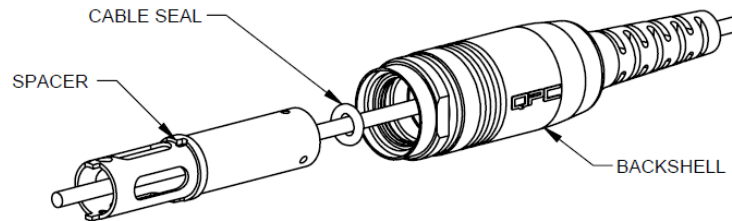

Remove approximately 6-inches (152mm) of the outer jacket from the cable end. Thread the Wedge Strain Relief Base over the fiber and Kevlar and slide it to the cable jacket edge. Thread the Wedge Strain Relief Insert over the fibers. Spread the Kevlar out evenly and slide the Wedge Strain Relief Insert into the Wedge Strain Relief Base. The Kevlar should be trapped between the Wedge Strain Relief Base and the Wedge Strain Relief Insert. Cut Kevlar flush with top of Strain Relief Wedge.

Screw on Wedge Strain Relief Cap to the Wedge Strain Relief Base. Tighten using the Dial Torque-Measuring Wrench PT-506 and Crow’s Foot Wrench PT-536 and torque to the values in the above Torque Table.

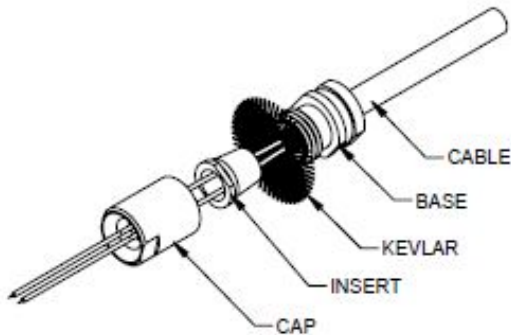

TERMINATION

Use the Stripping Length Diagrams located in the Appendix with the Fiber Optic Termination and Polishing Assembly Instructions (reference CAI-TERM) to terminate each fiber.

POPULATE INSERT

Slide the Fiber Optic Termini into the Insert Cap according to the desired pinout. Assemble Insert Body to the back of the Insert Cap ensuring that the 900µm fiber slide into the side slots of the Insert Body to prevent pinching during assembly. Apply Loctite 243 on the Socket Head Cap Screw threads per manufacturer’s instructions or equivalent may be used and screw the Insert using Hex Driver PT-503 and Torque Driver PT-590 with Hex Bit 5/64” PT-599 to torque the Socket Head Cap Screws to the values in the above Torque Table.

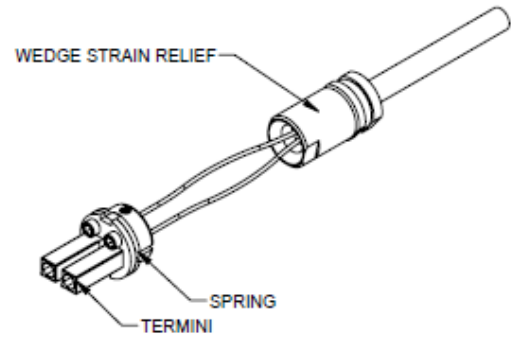
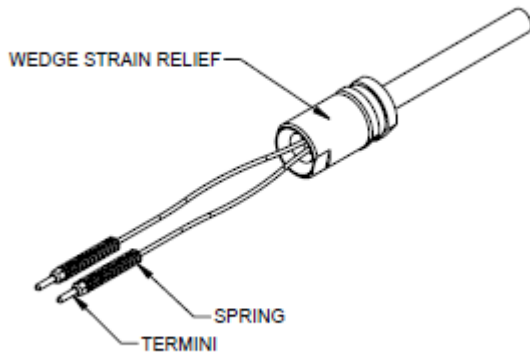

CONNECTOR ASSEMBLY

Slide the Spacer up and screw in the Flat Head Screws to the Insert Body using a Philips Screwdriver.

Pull Strain Relief to bottom of Spacer, apply Loctite on the Set Screw threads and tighten using Hex Driver PT-500. Use Torque Hex Driver PT-590 with Hex Bit .050" PT-599 and torque to the values in the above Torque Table.

Perform a visual check by looking through the holes in the Spacer to make sure that the fiber is not twisted or kinked.

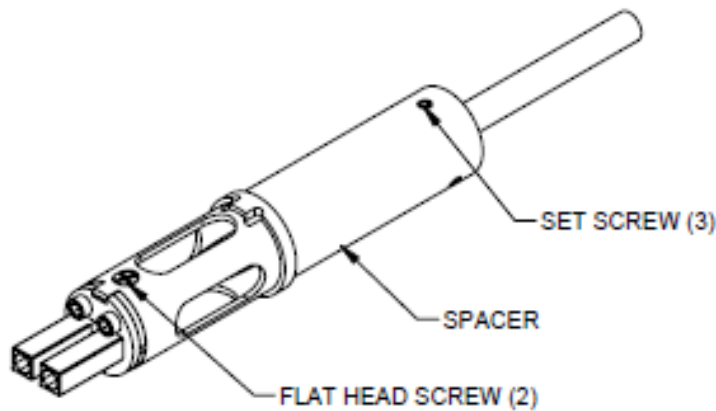

Place the Insert end into the Body Assembly. The keys on the Spacer should engage with the keyways in the Body Assembly.

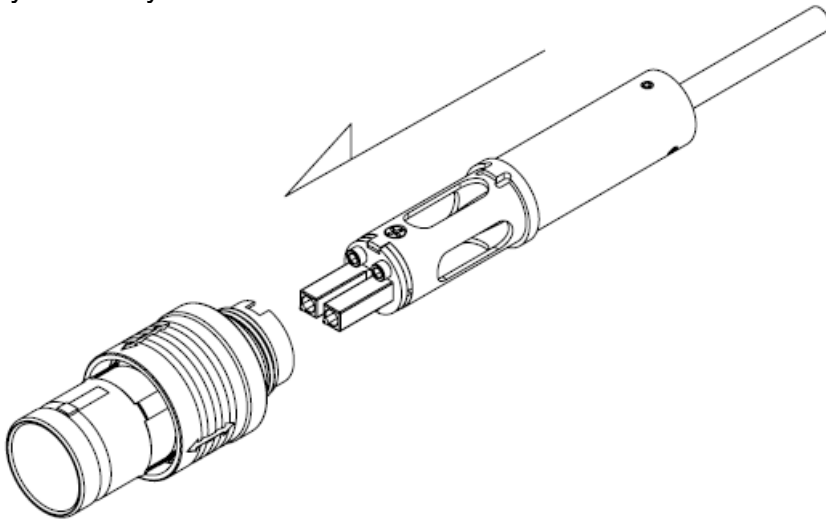

Slide the Backshell into position and tighten by hand onto the Body Assembly making sure that the Spacer does not turn relative to the Body. Insert the Plug Assembly onto the 2 Channel part of the Torque Fixture Stand PT-317. Torque the Backshell using Dial Torque-Measuring Wrench PT-506 with Crow's Foot Wrench PT-536 to the values in the above Torque Table. Make sure not to over torque the Backshell as this will cause damage.

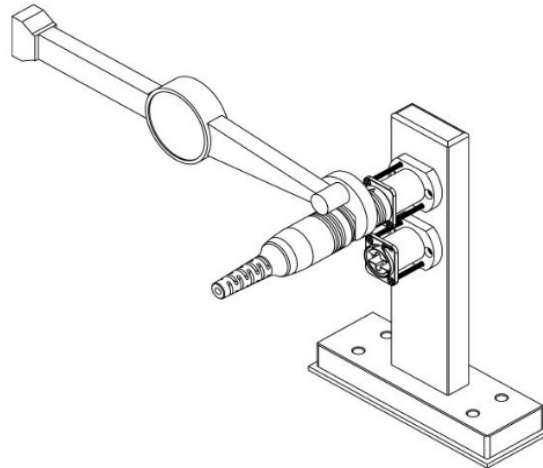
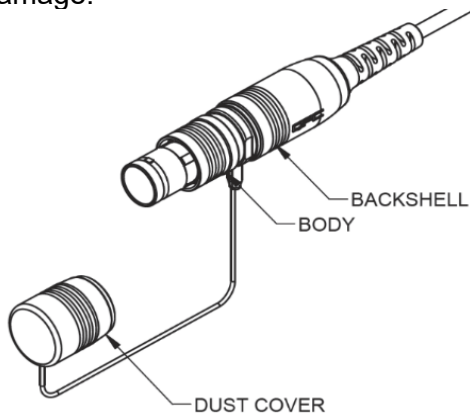

NOTE: After torquing, ensure that the insert is clocked properly in the Body with respect to the main key.

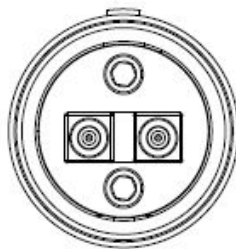

PLUG, 4 CHANNEL CONFIGURATION – Cable OD Range: 3.6mm to 6.5mm

CABLE PREPARATION

Slide parts onto cable in the order below.

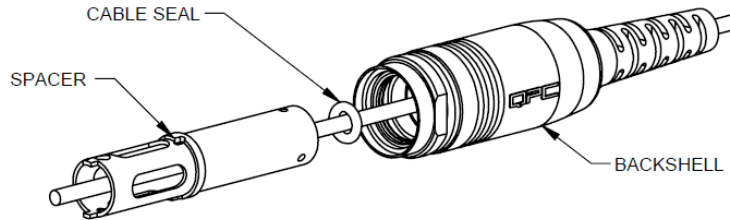

Strip cable jacket approximately 6" (152 mm) from end and place Crimp Support over fiber and Kevlar. Bend Kevlar back over the Crimp Support. Slide Crimp over Kevlar and Crimp Support to prepare for crimping.



Setup the Hydraulic Crimping tool PT-540 with the Die Set PT-541. The Crimp Die with Stop needs to be placed on the bottom facing out and with the Crimp against the stop as seen in the image below. Turn the knob clockwise on the Hydraulic Crimper, so that the handles can be pumped to crimp. Place the cable in the lower Crimp Die with the fiber facing out. Pump the handles until the Crimp Dies are touching. Release crimp by turning knob counterclockwise.

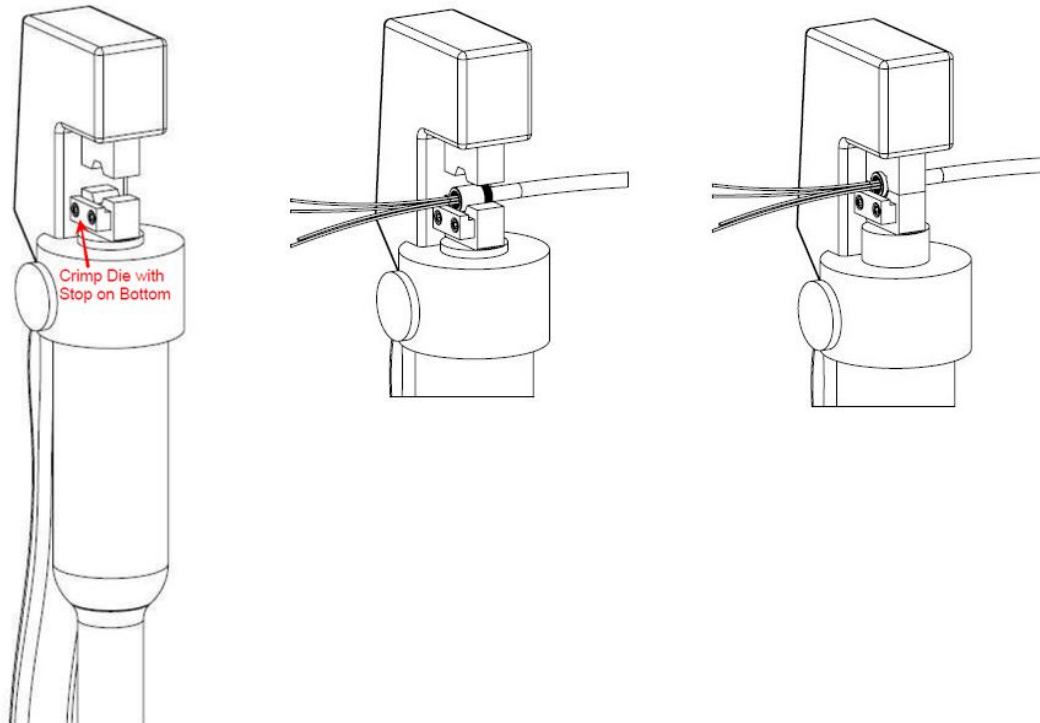

TERMINATION

Use the Stripping Length Diagrams located in the Appendix with the Fiber Optic Termination and Polishing Assembly Instructions (reference CAI-TERM) to terminate each fiber.

POPULATE INSERT

Slide the Fiber Optic Termini into the Insert Cap according to the desired pinout. Assemble Insert Body to the back of the Insert Cap ensuring that the 900µm fiber slide into the side slots of the Insert Body to prevent pinching during assembly. Apply Loctite 243 on the Socket Head Cap Screw threads per manufacturer’s instructions or equivalent may be used and screw the Insert using Hex Driver PT-503 and Torque Driver PT-590 with Hex Bit 5/64” PT-599 to torque the Socket Head Cap Screws to the values in the above Torque Table.

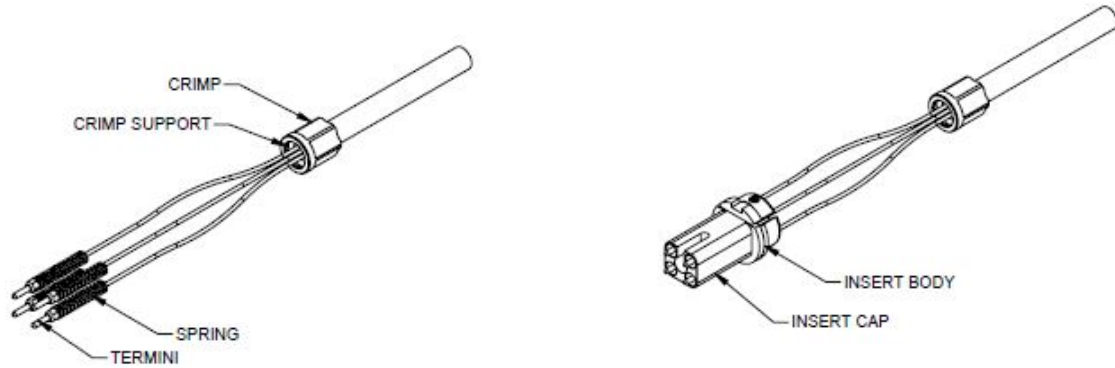

CONNECTOR ASSEMBLY

Slide the Spacer up and screw in the Flat Head Screws to the Insert Body using a Philips Screwdriver.

Pull Crimp to bottom of Spacer, apply Loctite on the Set Screw threads and tighten using Hex Driver PT-500. Use Torque Hex Driver PT-590 with Hex Bit .050” PT-599 and torque to the values in the above Torque Table.

Perform a visual check by looking through the holes in the Spacer to make sure that the fiber is not twisted or kinked.

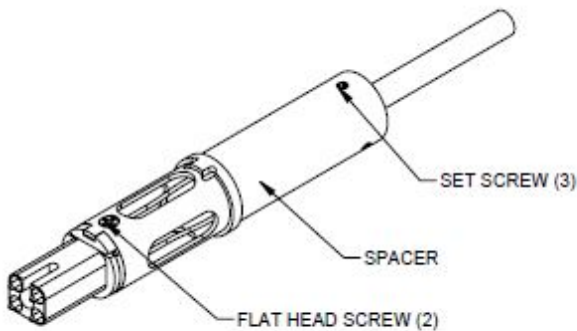

Place the Insert end into the Body Assembly. The keys on the Spacer should engage with the keyways in the Body Assembly.

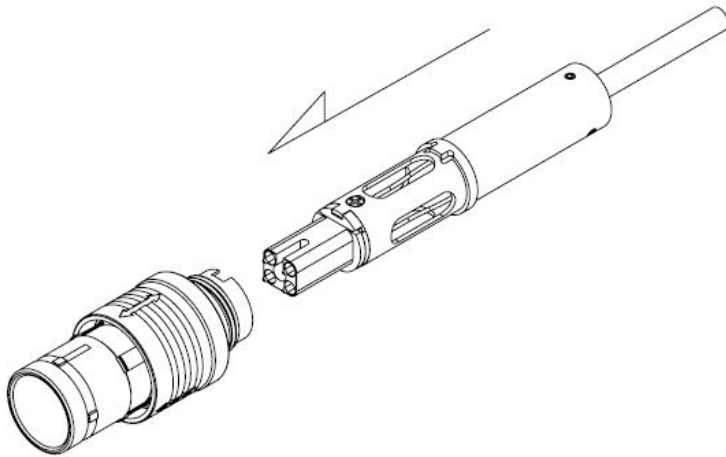

Slide the Backshell into position and tighten by hand onto the Body Assembly making sure that the Insert does not turn relative to the Body. Insert the Plug Assembly into the 4 Channel part of the Torque Fixture Stand PT-317. Torque the Backshell using Dial Torque-Measuring Wrench PT-506 with Crow's Foot Wrench PT-536 to the values in the above Torque Table. Make sure not to over torque the Backshell as this will cause damage.

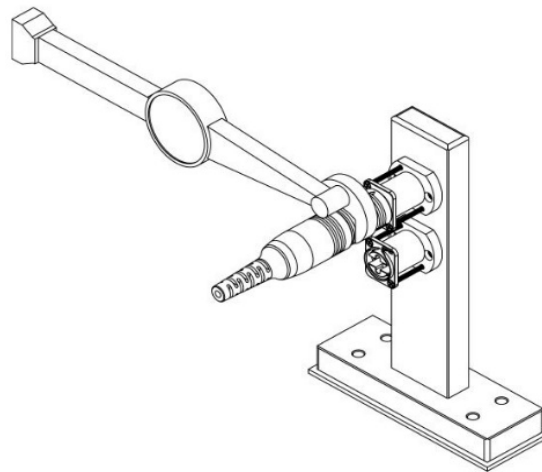
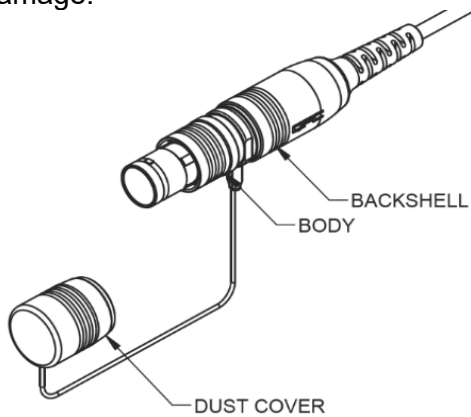

NOTE: After torquing, ensure that the insert is locked properly in the Body with respect to the main key.

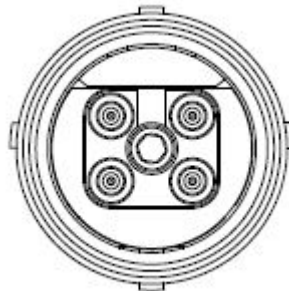

PLUG, 4 CHANNEL CONFIGURATION – Cable OD Range: 6.6mm to 10.5mm

CABLE PREPARATION

Slide parts onto cable in the order below.

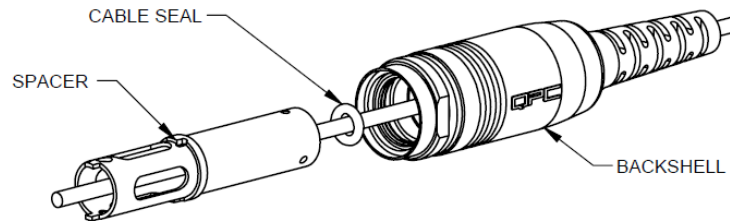

Remove approximately 6-inches (152mm) of the outer jacket from the cable end. Thread the Wedge Strain Relief Base over the fiber and Kevlar and slide it to the cable jacket edge. Thread the Wedge Strain Relief Insert over the fibers. Spread the Kevlar out evenly and slide the Wedge Strain Relief Insert into the Wedge Strain Relief Base. The Kevlar should be trapped between the Wedge Strain Relief Base and the Wedge Strain Relief Insert. Cut Kevlar flush with top of Strain Relief Wedge.

Screw on Wedge Strain Relief Cap to the Wedge Strain Relief Base. Tighten using the Dial Torque-Measuring Wrench PT-506 and Crow's Foot Wrench PT-536 and torque to the values in the above Torque Table.

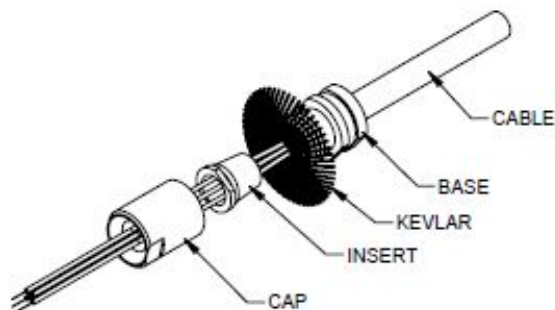

TERMINATION

Use the Stripping Length Diagrams located in the Appendix with the Fiber Optic Termination and Polishing Assembly Instructions (reference CAI-TERM) to terminate each fiber.

POPULATE INSERT

Slide the Fiber Optic Termini into the Insert Cap according to the desired pinout. Assemble Insert Body to the back of the Insert Cap ensuring that the 900µm fiber slide into the side slots of the Insert Body to prevent pinching during assembly. Apply Loctite 243 on the Socket Head Cap Screw threads per manufacturer's instructions or equivalent may be used and screw the Insert using Hex Driver PT-503 and Torque Driver PT-590 with Hex Bit 5/64" PT-599 to torque the Socket Head Cap Screws to the values in the above Torque Table.

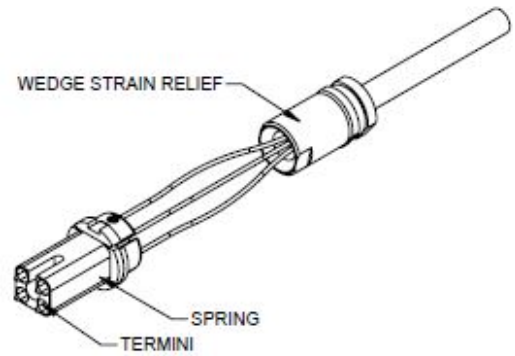
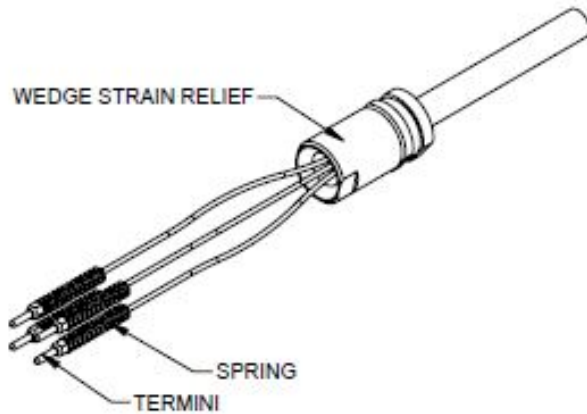

CONNECTOR ASSEMBLY

Slide the Spacer up and screw in the Flat Head Screws to the Insert Body using a Philips Screwdriver.

Pull Strain Relief to bottom of Spacer, apply Loctite on the Set Screw threads and tighten using Hex Driver PT-500. Use Torque Hex Driver PT-590 with Hex Bit .050" PT-599 and torque to the values in the above Torque Table.

Perform a visual check by looking through the holes in the Spacer to make sure that the fiber is not twisted or kinked.

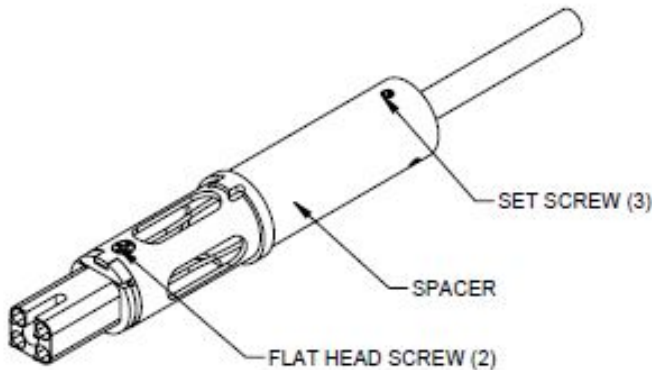

Place the Insert end into the Body Assembly. The keys on the Spacer should engage with the keyways in the Body Assembly.

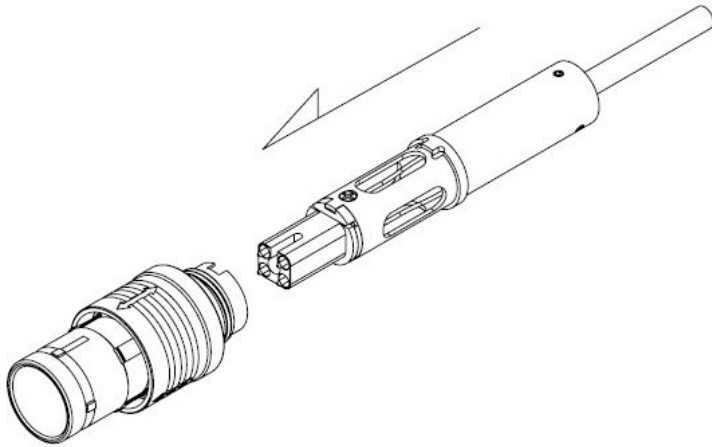

Slide the Backshell into position and tighten by hand onto the Body Assembly making sure that the Spacer does not turn relative to the Body. Insert the Plug Assembly onto the 4 Channel part of the Torque Fixture Stand PT-317. Torque the Backshell using Dial Torque-Measuring Wrench PT-506 with Crow's Foot Wrench PT-536 to the values in the above Torque Table. Make sure not to over torque the Backshell as this will cause damage.

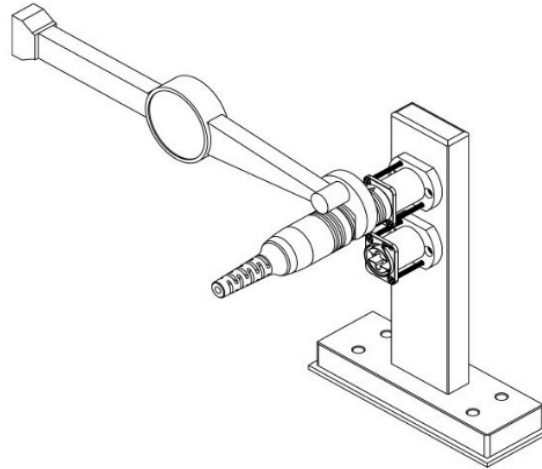
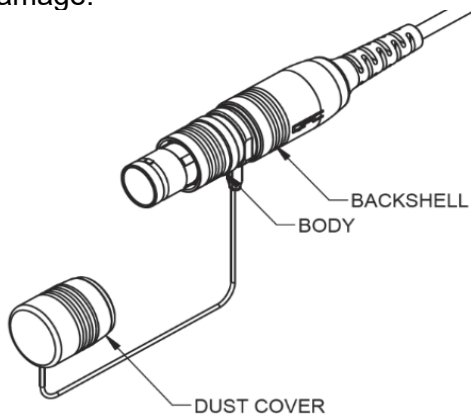

NOTE: After torquing, ensure that the insert is clocked properly in the Body with respect to the main key.

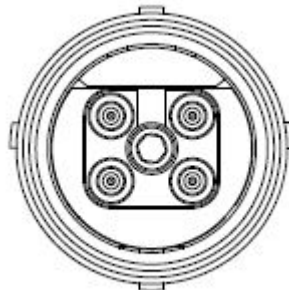

Appendix

STRIPPING LENGTHS – QSEAL PLUG ALL CONFIGURATIONS

- WI 851-62 - FIGURE 2.1 – QSEAL 2 CHANNEL CONFIGURATION
- WI 851-62 - FIGURE 2.2 – QSEAL 4 CHANNEL CONFIGURATION
- WI 851-62 - FIGURE 2.3 – QSEAL 2 CHANNEL CONFIGURATION LARGE CABLE
- WI 851-62 - FIGURE 2.4 – QSEAL 4 CHANNEL CONFIGURATION LARGE CABLE

Revision Change Record

Revision	Date	Section	Description	Approval
1	11/15/2021	New Release	New Release	CN

Q-SEAL PLUG, 2 CHANNEL

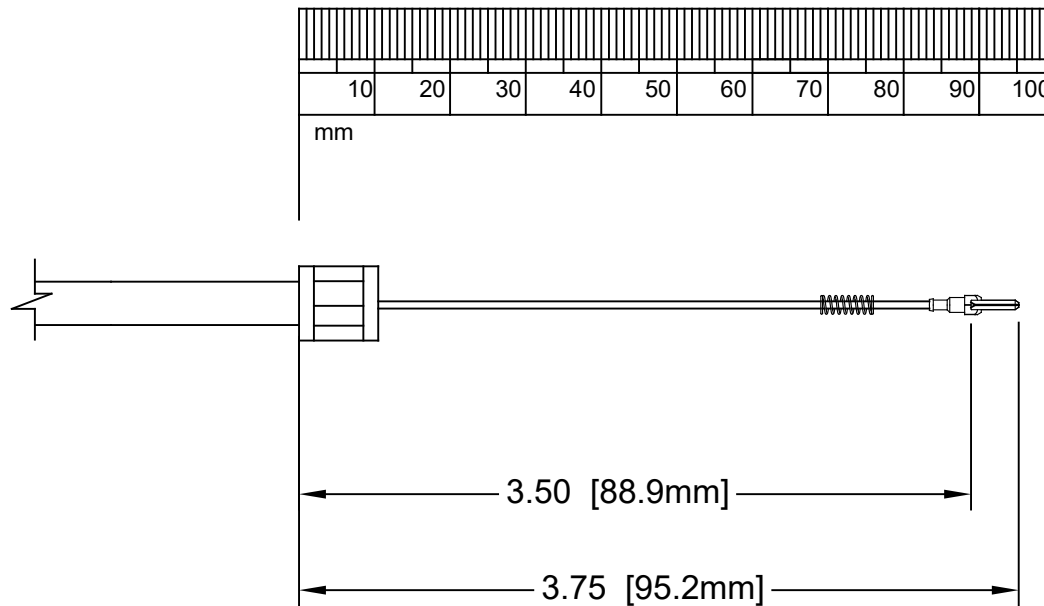

Q-SEAL PLUG, 4 CHANNEL

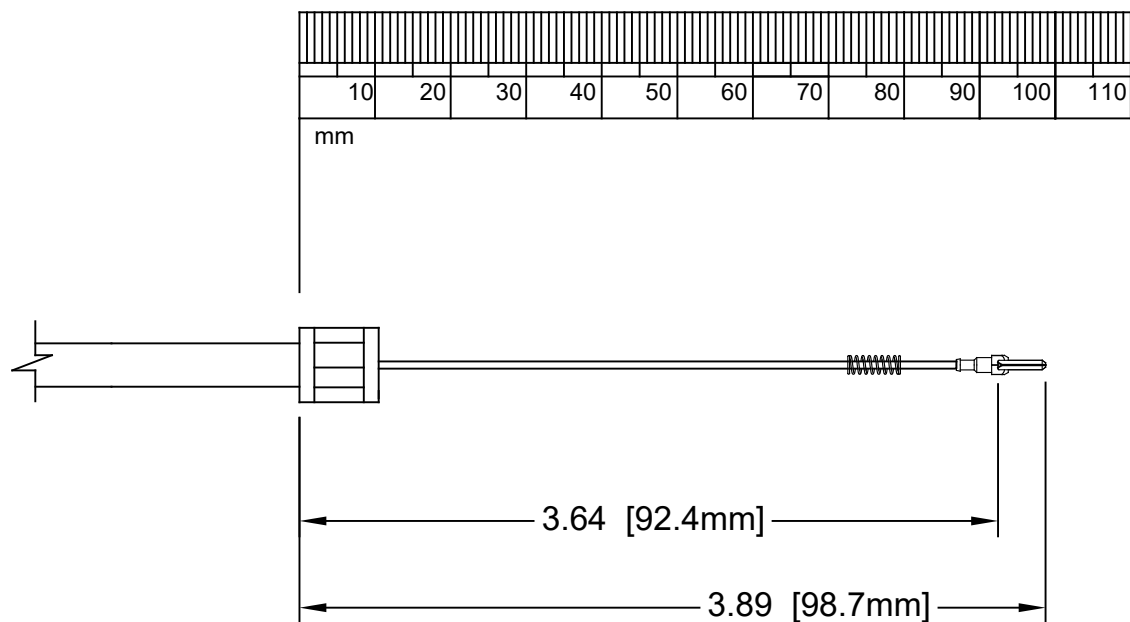

Q-SEAL PLUG, 2 CHANNEL, LARGE CABLE

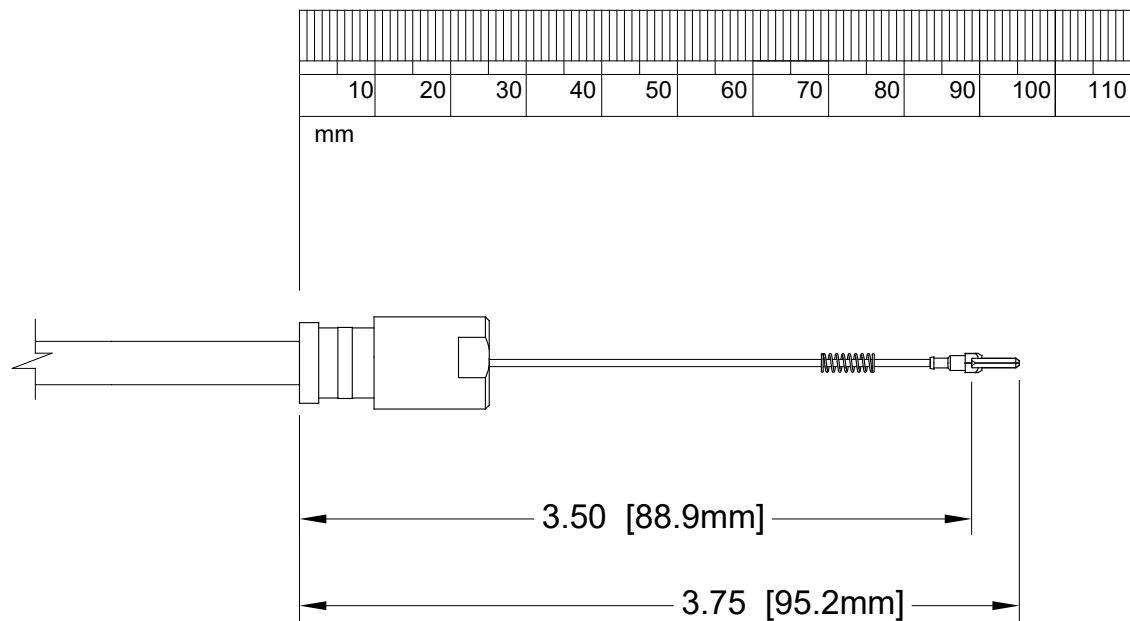

Q-SEAL PLUG, 4 CHANNEL, LARGE CABLE

