

QPlex3 Connector Plug Assembly Instructions

(For Large & Standard Cables Sizes)

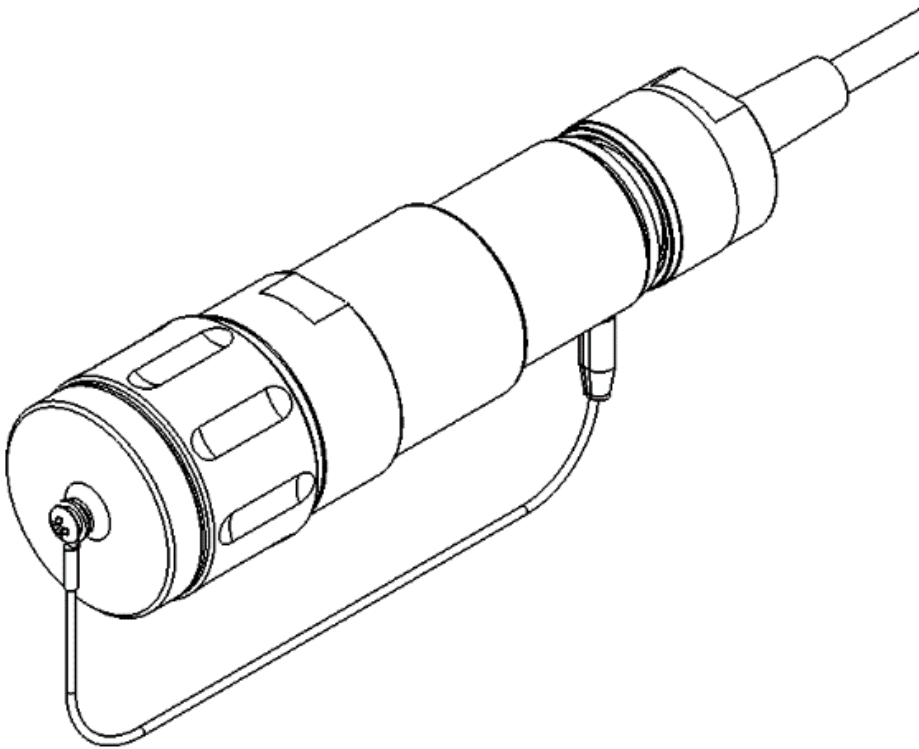

DOCUMENT:	AIQP-05
REVISION:	0
REVISION DATE:	3/28/2019
ENGINEERING RELEASE:	19-0576

QPC CONFIDENTIAL

THE INFORMATION CONTAINED IN THIS DOCUMENT IS THE SOLE PROPERTY OF QPC FIBER OPTIC. ANY REPRODUCTION IN PART OR AS A WHOLE WITHOUT THE WRITTEN PERMISSION OF QPC FIBER OPTIC IS PROHIBITED.

Document: AIQP-05
Release Date: 3/28/2019



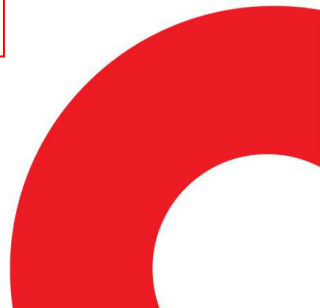







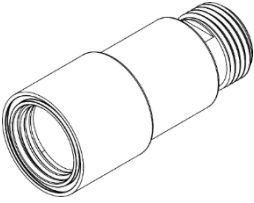
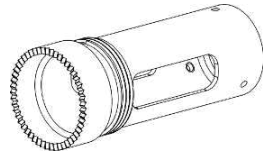

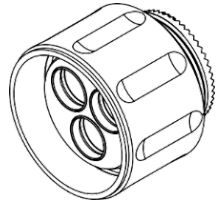
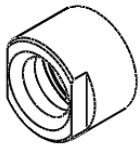
Revision: 0
Revision Date: 3/28/2019

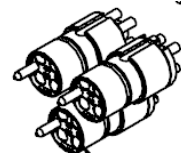

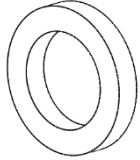
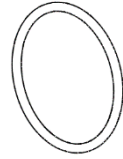
SCOPE

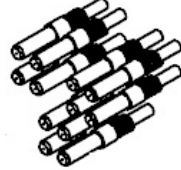
This document will describe the assembly instructions for the QPlex3 Connector Assembly for Larger and Standard cable diameter sizes.

COMPONENTS

				
BACKSHELL COVER	BACKSHELL BODY	COUPLING RING	STRAIN RELIEF BACKNUT	PLUG BODY
				
NUT, WEDGE STRAIN RELIEF	INSERT, WEDGE STRAIN RELIEF	BODY, WEDGE STRAIN RELIEF	INSERT (X3)	RETAINER PLATE & SCREW
				
SQUARE O-RINGS (x2)	O-RING(S)	SET SCREWS(x3)	TERMINI (X12) w/12 springs	Wave Spring (x3)
				
RETAINER	SPACER			

Document: AIQP-05	Revision: 0
Release Date: 3/28/2019	Revision Date: 3/28/2019



OPTIONAL COMPONENTS

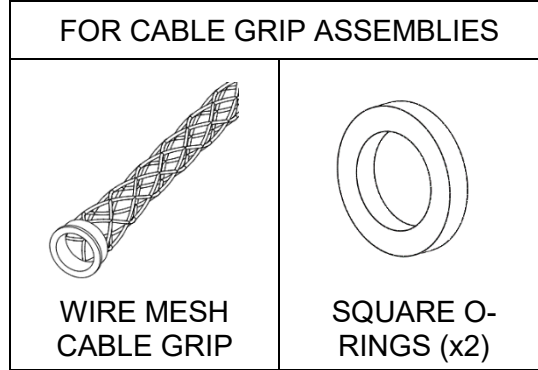
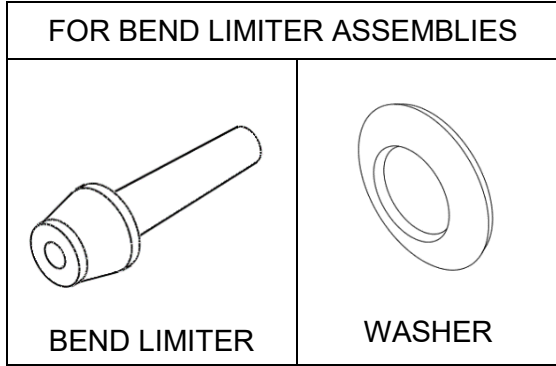

TOOLS AND MATERIALS

PT-062 Miller Kevlar Scissors	PT-506 Dial Torque-Measuring Wrench
PT-500 Hex Driver – 1.3 mm Tip	PT-532 Needle Nose Tweezers
PT-504 Hex Driver – 2.0 mm Tip	PT-540 Crimp Tool
PT-518 Crowfoot Wrench - 1-3/8 Inch	PT-526 Crowfoot Wrench - 1 Inch
PT-513 Crowfoot Wrench - 3/4 Inch	

TORQUE TABLE

QPllex3 Part	Torque Value: Inch / Pounds		Torque Value: Newton Meters	
	Min	Max	Min	Max
Back Nut	62	66	7	7.5
Backshell	62	66	7	7.5
Coupling Ring	62	66	7	7.5
Strain Relief Wedge				
	97	115	11	13

Document: AIQP-05	Revision: 0
Release Date: 3/28/2019	Revision Date: 3/28/2019



CONNECTOR PREPARATION

Unscrew Backshell Cover from Backshell Body & Coupling Ring. Unscrew Strain Relief Back Nut from Backshell Cover. Use hex driver PT-504 to loosen set screws from Spacer.

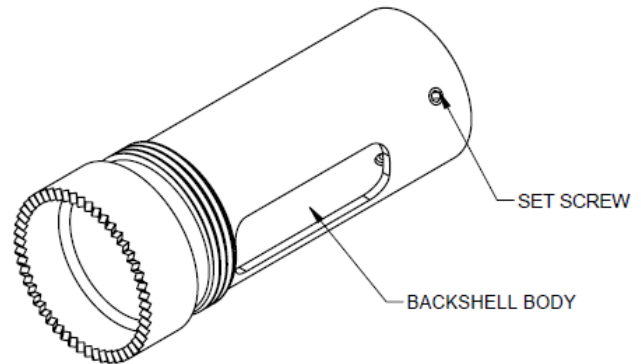

CABLE PREPARATION

For Larger Diameter Cables, slide parts over cable in the following order:

1. Label (if applicable)
2. Strain Relief Backnut
3. Wire Mesh Cable Grip
4. Square O-Ring x2
5. Backshell Cover
6. O-Ring
7. Coupling Ring
8. Backshell Body
9. O-Ring
10. Wedge Strain Relief in Order Seen in Image
11. Spacer

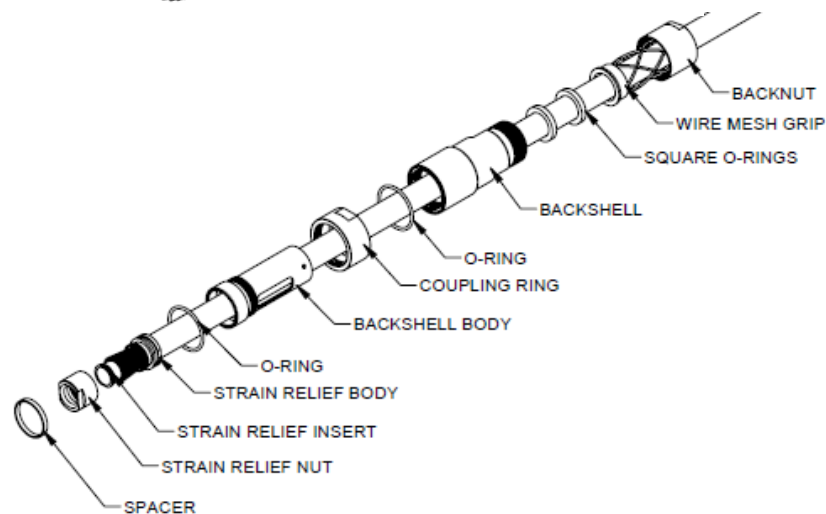

For Standard Diameter Cables, slide parts over cable in the following order:

1. Label (if applicable)
2. Strain Relief Back Nut
3. Washer
4. Bend Limiter
5. Backshell Cover
6. O-Ring
7. Coupling Ring
8. Backshell Body
9. O-Ring
10. Spacer

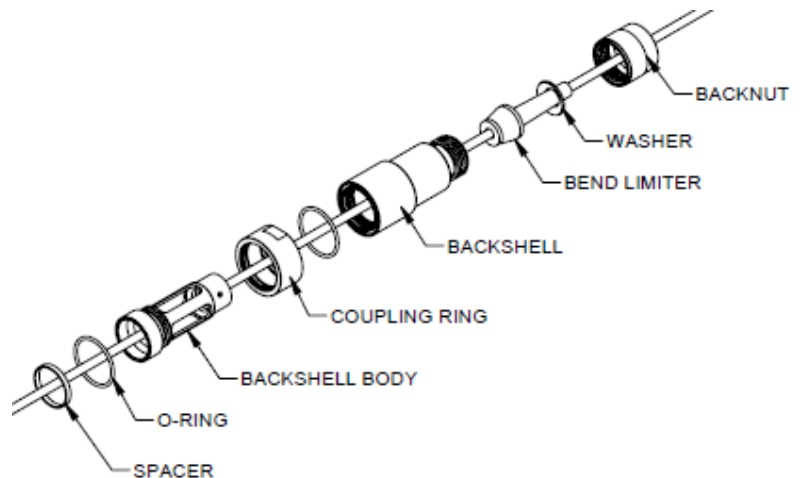

CABLE ANCHOR (Large Diameter Cable)

Remove Cap, Insert, and Base of Wedge Strain Relief from bag.

Remove approximately 5 inches of the outer jacket from the cable. Thread the wedge strain relief base over the fiber and strength member (Kevlar) up to the cable jacket. Thread the insert over the fibers. Spread the strength member out evenly and push the insert into the base. The yarn should be trapped between the base and the insert. Trim off the excess yarn. Thread the cap over fiber, screw it onto the base and tighten according to the values in the torque table.

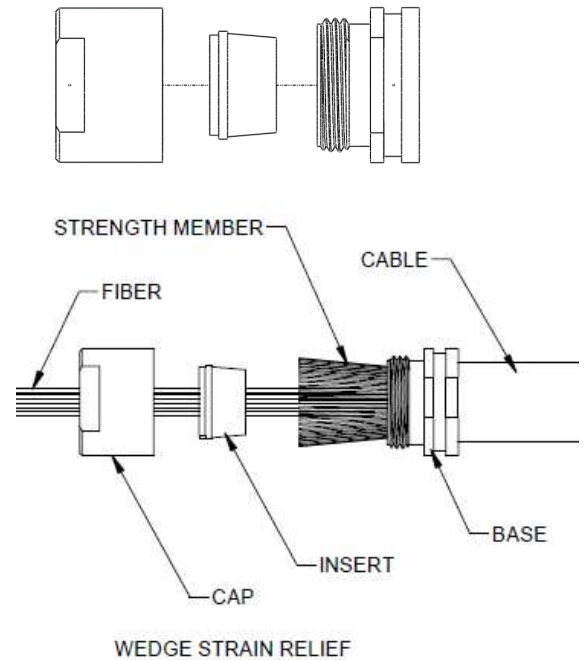

TERMINATE

Terminate and polish the fiber using the provided Termini. Follow stripping lengths in diagram below.
NOTE: Include a Spring on each of the fibers.

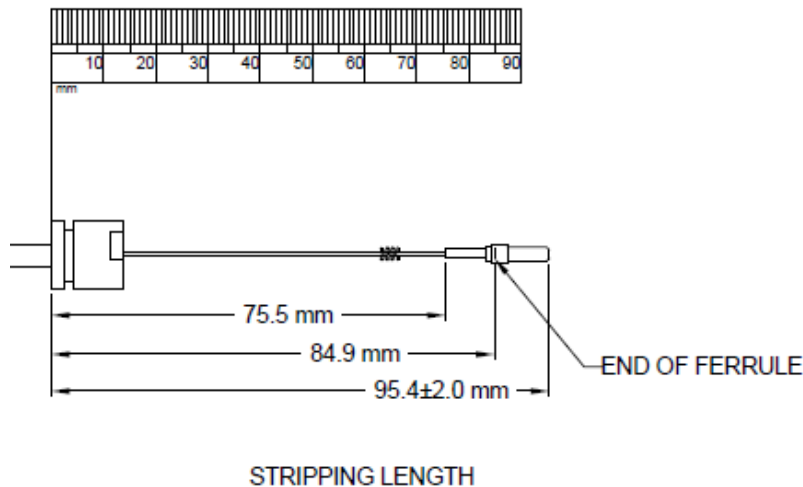

Document: AIQP-05	Revision: 0
Release Date: 3/28/2019	Revision Date: 3/28/2019



POPULATE INSERT

Insert the fibers into the back of the inserts. Consult the cable specifications for color code.

NOTE: Handle insert with caution, do not touch front face or lens.

Using needle nose tweezers, place the retainer plate between jacketed fibers.

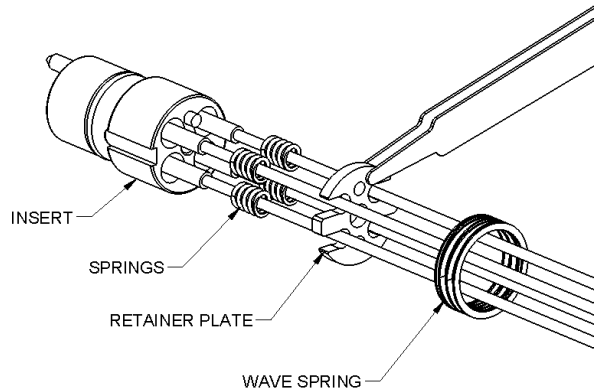

Apply a drop of Loctite 222 to the socket head cap screw.

Secure by tightening the retainer plate with the socket head cap screw using a 2.0 mm PT-504 hex driver.

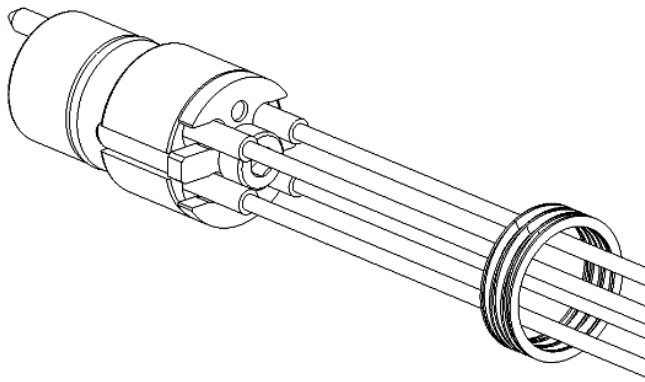

Slide the inserts into the Plug Body. Consult the cable specification for the fiber map. Slide the Wave Spring in behind the insert. The front of the insert should protrude slightly from the front of the connector

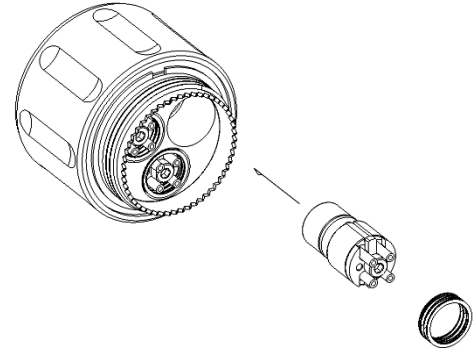

Position the Retainer and the Spacer in the back of the Connector Body Plug

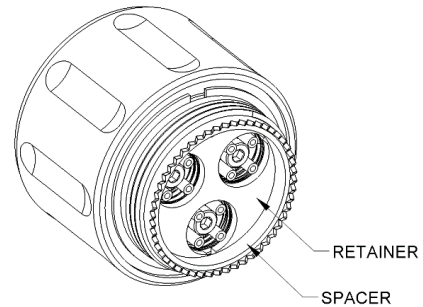

FINAL ASSEMBLY

Mount the plug on a receptacle body.
Slide the Backshell Body and Coupling Ring into position. The first O-Ring will go between the Coupling Ring and the Connector Body. Torque the Coupling Ring according to the values in Torque Table. Secure the crimp with the set screws. Apply a drop of Loctite 242 to the set screws. Testing as required can be done at this point.

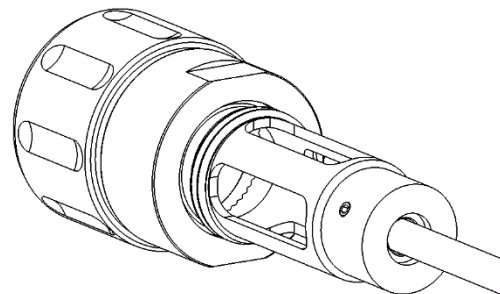

Slide the Backshell with the final O-ring over the assembly and Torque the Backshell Cover according to the values in the Torque Table.

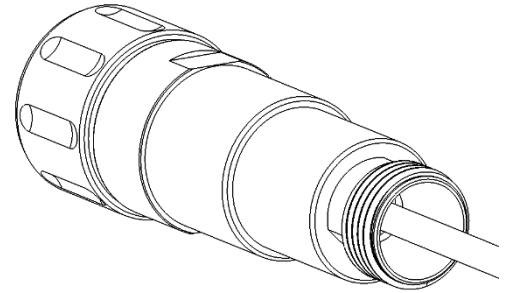

Slide the Wire Mesh Cable Grip and Back Nut (or Bend Limiter) into position and tighten the Back Nut according to the values in the above Torque Table.

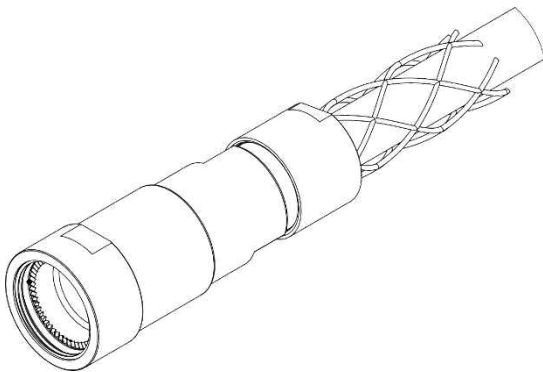

FOR: Wire Mesh Cable Grip

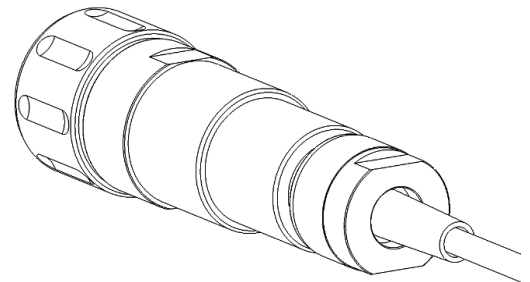

FOR: Bend Limiter

Attach the dust cap and lanyard.

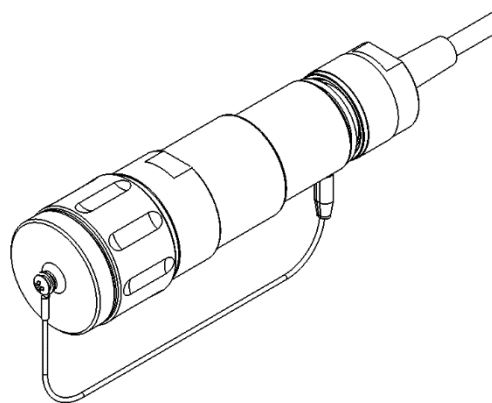

Document: AIQP-05	Revision: 0
Release Date: 3/28/2019	Revision Date: 3/28/2019

