

# QLink Receptacle Customer Assembly Instructions

## Jam Nut & Flange Mount

Threaded / Hermaphroditic / Reverse Bayonet / Push Pull

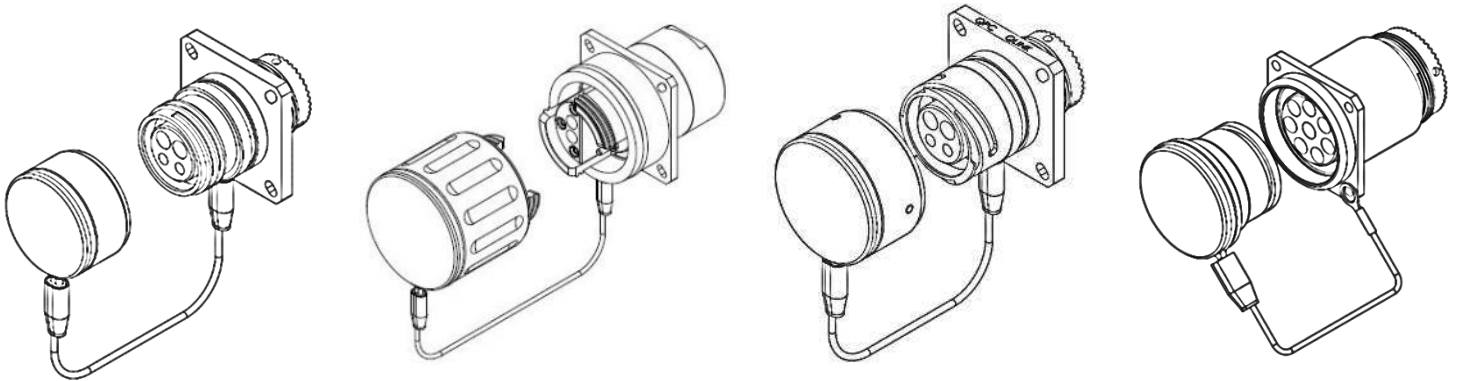

DOCUMENT: CAI-QLR-01  
REVISION: 0  
REVISION DATE: 8/13/2019

**QPC CONFIDENTIAL**

**THE INFORMATION CONTAINED IN THIS DOCUMENT IS THE SOLE PROPERTY OF QPC FIBER OPTIC. ANY REPRODUCTION IN PART OR AS A WHOLE WITHOUT THE WRITTEN PERMISSION OF QPC FIBER OPTIC IS PROHIBITED.**

Document: CAI-QLR-01  
Release Date: 08/13/2019

Revision: 0  
Revision Date: --/--/----









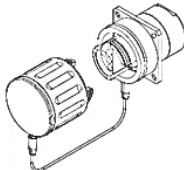
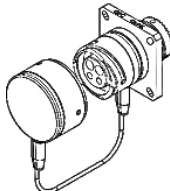
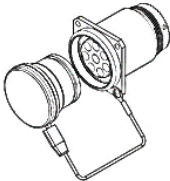

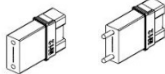
## SCOPE

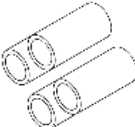
This document will describe the Assembly Instructions for the QLink Receptacle Jam Nut and Flange Mount Connector in the Threaded, Hermaphroditic, Reverse Bayonet and Push Pull configurations for all cable sizes.

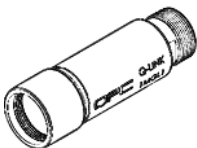
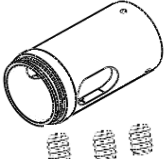

## MAIN COMPONENTS

<p><b>THREADED CONFIGURATION</b></p>  <p>BODY W/ INSERT &amp; DUST COVER</p>	<p><b>HERMAPHRODITIC CONFIGURATION</b></p>  <p>BODY W/ INSERT, DUST COVER &amp; BACK NUT</p>	<p><b>REVERSE BAYONET CONFIGURATION</b></p>  <p>BODY W/ INSERT &amp; DUST COVER</p>	<p><b>PUSH PULL CONFIGURATION</b></p>  <p>BODY W/ INSERT &amp; DUST COVER</p>
---	---	---	--

TERMINI OPTIONS	
 <p>FIBER OPTIC TERMINI PINS / SOCKETS</p>	 <p>MT FERRULES</p>
 <p>CONTACT PINS / SOCKETS</p>	 <p>CRIMP SLEEVES</p>

BACKSHELL CONFIGURATION OPTIONS		
 <p>CAP WEDGE STRAIN RELIEF</p>	 <p>INSERT WEDGE STRAIN RELIEF</p>	 <p>BASE WEDGE STRAIN RELIEF</p>
 <p>BACKSHELL COVER</p>	 <p>SPACER &amp; 3 SET SCREWS</p>	 <p>BACKNUT</p>

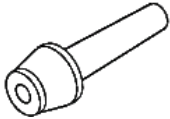
## STRAIN RELIEF COMPONENTS

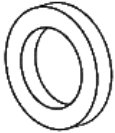
BOOT / BEND LIMITER OPTION		WIRE MESH GRIP OPTION	
 <p>BEND LIMITER</p>	 <p>WASHER</p>	 <p>WIRE MESH GRIP</p>	 <p>SQUARE O-RINGS x2</p>

## TOOL LIST

<b>TK-054 QPC QLink Tool Kit – (Equivalent tools may be used)</b>	
PT-117	QLink Fiber Optic Termini / Size 8 & Size 12 Contact Insertion Tool
PT-596	QLink Size 16 Contact Insertion Tool
PT-446	QLink Fiber Optic Termini Removal Tool
PT-445	QLink Size 16 Contact Removal Tool
PT-449	QLink Size 12 Contact Removal Tool
PT-443	QLink Size 8 Contact Removal Tool
PT-480	MT Fiber Optic Termini Insertion / Removal Tool
PT-005	Fiber Optic Termini Crimp Tool, 2mm, 3mm (Hex Sizes .100 / .147)
PT-560	Standard Adjustable Indent Crimp Tool M22520/1-01, Size 16 Contact
PT-562	Turret Head, Size 16, Pin and Socket, 26-14 AWG (Use with PT-560)
PT-561	Adjustable Hand Crimp Tool, Size 8 & Size 12 Contact
PT-563	Single Position Head, Size 12, Pin and Socket, 14-12 AWG (Use with PT-561)
PT-564	Single Position Head, Size 8, Pin and Socket, 12-8 AWG (Use with PT-561)
PT-589	Socket Fiber Optic Termini Sleeve Retainer Torque Tool
<b>TK-060 QPC Cable and Connector Prep Tool Kit – (Equivalent tools may be used)</b>	
PT-062	Miller Kevlar Scissors (Carbon Molybdenum & Vanadium Steel Blade)
PT-500	Precise-Control .050" Screwdriver (1.27mm) Hex
PT-501	Precise-Control Screwdriver, 1/16" Hex
PT-503	Precise-Control Screwdriver, 5/64" (2mm) Hex
PT-502	Precise-Control Screwdriver, 3/32" Hex
PT-504	Precise-Control Screwdriver, 2.5mm Hex
PT-505	Screwdriver, Number 1 Phillips, 6-3/4" Overall Length
PT-506	Dial Torque-Measuring Wrench, 3/8" Square Drive, 0 to 150in.-lbs. and 0 to 18NM Torque
PT-536	Crow's Foot Wrench Adjustable 3/8" Square Drive 0.0-1.125"(0-28.57mm) - (For Shell Sizes 13 – 19)
PT-545	Crow's Foot Wrench Adjustable 1/2" Square Drive .236-1.771" (6-45mm) - (For Shell Sizes 21 – 31)
PT-546	3/8" Female x 1/2" Male Square Drive Adapter, Chrome
PT-532	Long-Nose Pliers with Flat Jaws, Cushion Grip, 6-3/4" Overall, Manual Jaws with Wire Cutter
PT-599	Hex Bit Set, 5 pcs (.050", 1/16", 5/64", 3/32", 2.5mm) 1/4" Shank, Overall Length 2"
PT-590	Torque-Measuring Screwdriver, Hex Drive, 2.5 to 11.5 in.-lbs. Adjustable Torque
PT-591	4" Drill Press Vise with 2 x Machined Plastic Jaws with Groove

## TORQUE TABLE

Component	Backshell / Backnut			Strain Relief	Set Screws	Sleeve Retainer
Shell Size	13 – 15	17 – 19	21 – 31	All	All	All
Torque Values	80 – 97 in-lb	89 – 106 in-lb	106 – 124 in-lb	97 – 115 in-lb	5 – 6 in-lb	2 – 3 in-lb
	9 – 11 N • m	10 – 12 N • m	12 – 16 N • m	9 – 11 N • m	.56 – .68 N • m	.23 – .34 N • m

## CABLE PREPARATION

### For Cable Options with Backshell Configuration

Slide parts over cable in the following order:

1. Label (if applicable)
2. Backnut
3. Cable Grip OR Washer
4. Square O-Ring (x 2) OR Bend Limiter
5. Backshell Cover
6. Spacer

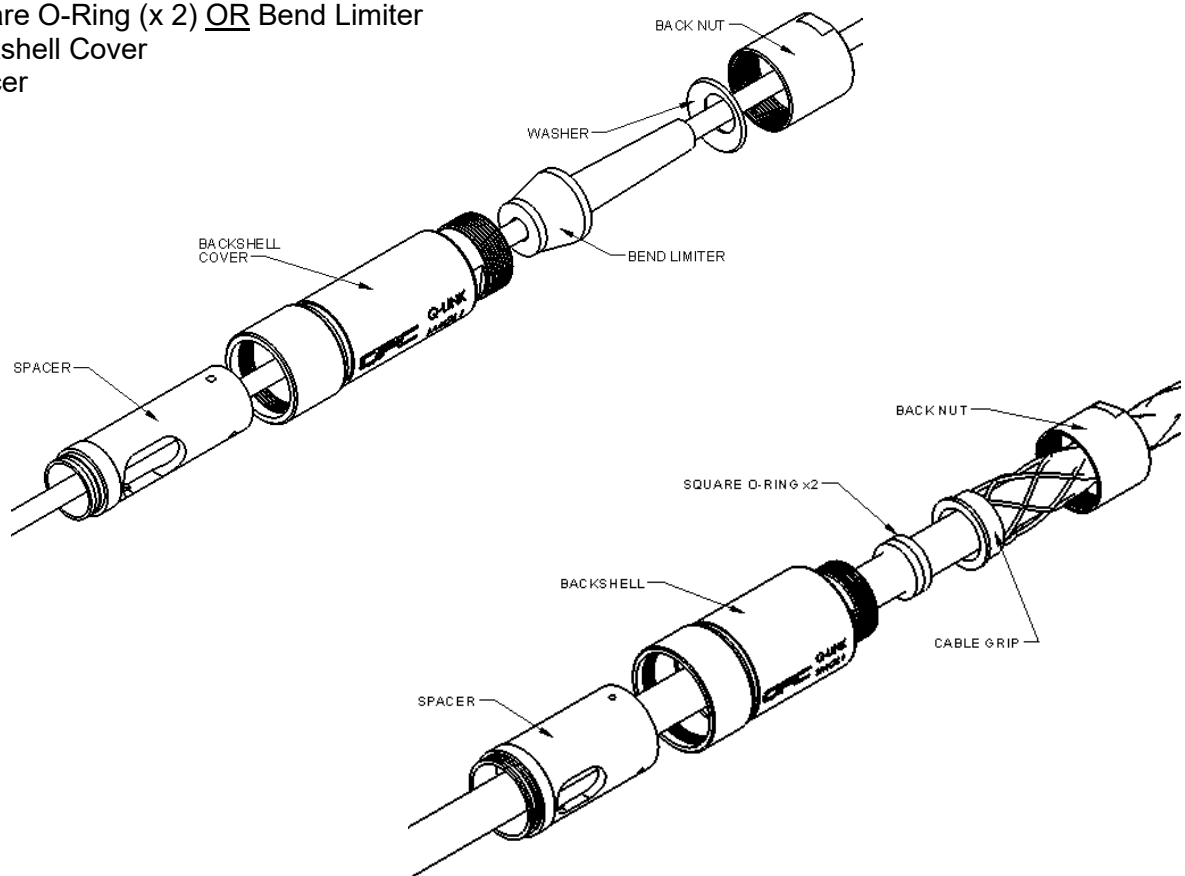

Strip cable jacket 6" from end. Separate Kevlar and remove any additional cable elements with Kevlar Scissors PT-062.

Slide base of wedge strain relief back to jacket edge. Slide Insert of wedge strain relief inside base and push between the Kevlar and the individual fibers / wires.

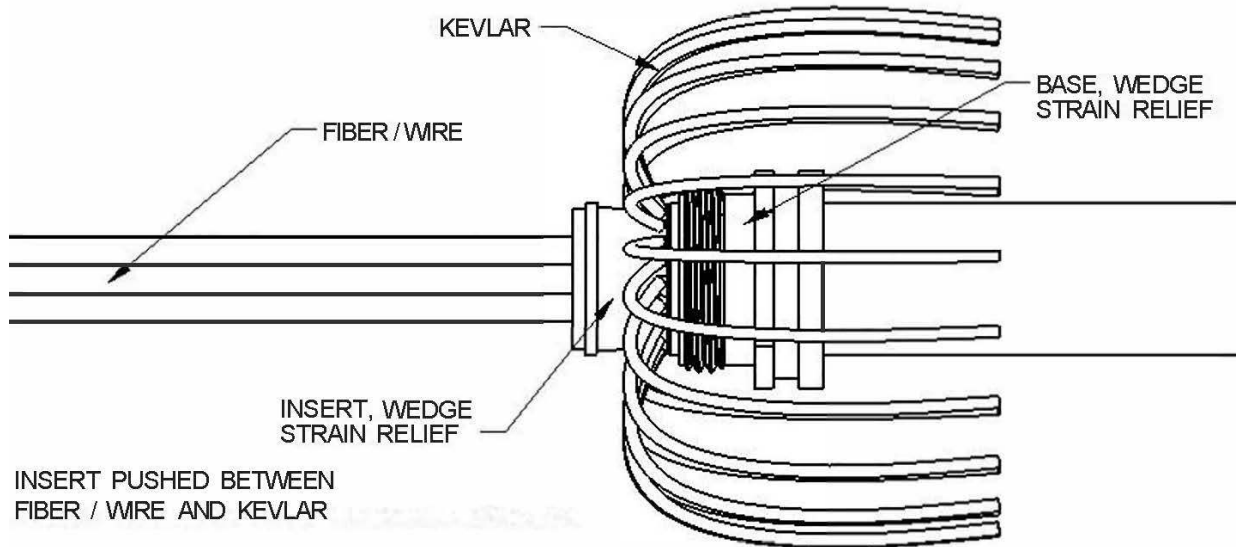

Cut Kevlar flush with top of wedge. Screw on Cap of Wedge Strain Relief. Torque to tighten using values from Torque Table above.

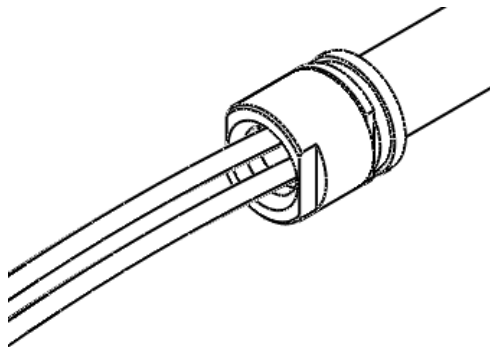

## TERMINATE

### For Cable Options with Backshell Configurations

Use the Stripping Length Diagrams in the Appendix located in the back of this Assembly Instruction for the desired connector configuration to Terminate and polish the fiber and install the Electrical Contacts using the provided Fiber Optic Termini / Contacts. For Fiber Optic / Wire Termination and Polishing details, reference CAI-TERM-02.

### For 2mm or 3mm Cable Options

Slide the Crimp Sleeve onto the cable and strip the cable according to the lengths in the diagram below for Pin or Socket Fiber Optic Termini. Leave 5/16-Inches (8mm) of Kevlar on the cable for crimping. Thread the bare fiber through the back of the Termini making sure that the fiber slides through the other end of the Ferrule. Slide the Kevlar under the Crimp Sleeve. Use Fiber Optic Termini Crimp Tool PT-005 (Hex Size .147) to crimp the Crimp Sleeve into place. For Fiber Optic / Wire Termination and Polishing details, reference CAI-TERM-02.

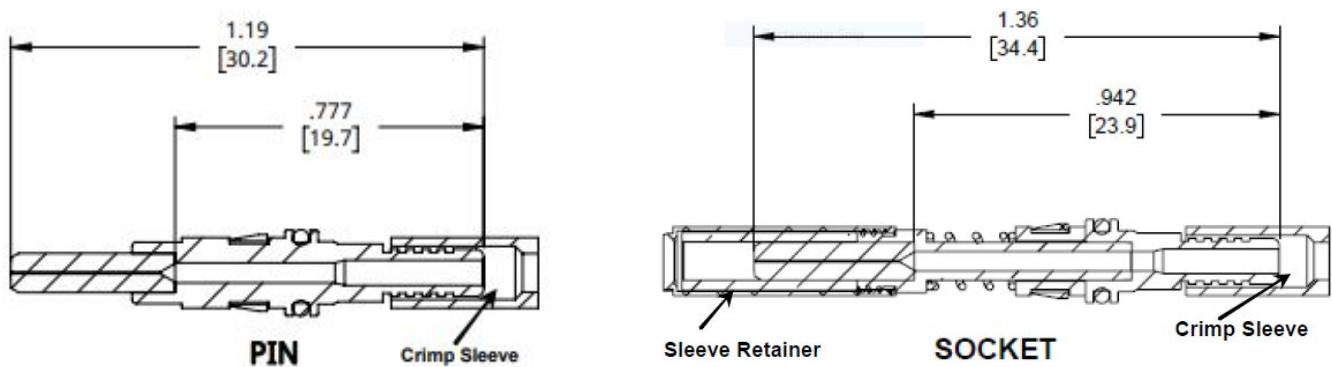

Note: After Polishing Sockets, slide the Split Alignment Sleeve over the Fiber Optic Termini and then slide the Sleeve Retainer over the Split Alignment Sleeve to the base of the Fiber Optic Termini. Apply Vibra-Tite VC-3 Threadmate on the threads per manufacturer's instructions. Screw the Sleeve Retainer onto the thread of the Fiber Optic Termini. Torque using the Sleeve Retainer Torque Tool PT-589 to the torque values in the torque table above.

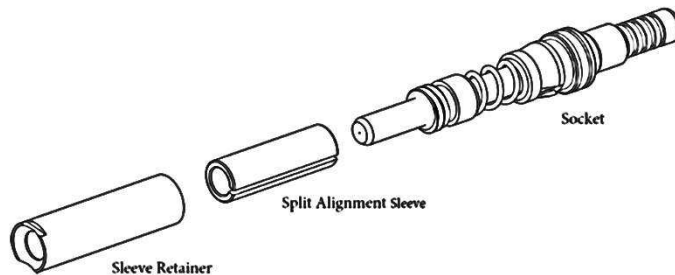

## POPULATE INSERT

Use appropriate Insertion (Tool PT-117 or PT-596) to insert Fiber Optic Termini or Contacts according to the desired pinout (varies by connector size and channel count). Image below shows a hybrid insert.

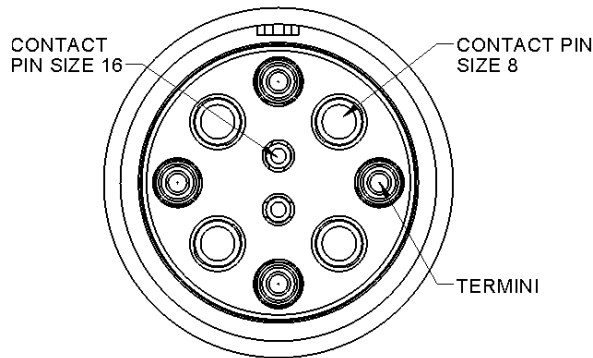

When populating using APC Fiber Optic Termini, align the key on the Fiber Optic Termini with keyway in the Insert.

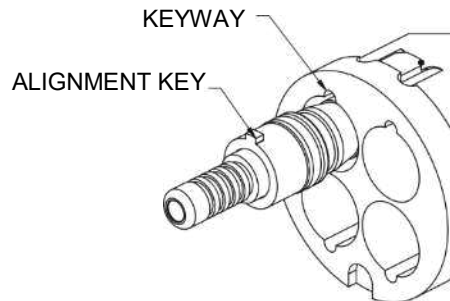

**For Hermaphroditic Insert** – Push in Fiber Optic Termini / Contact Pin and Sockets through back of Insert using appropriate Insertion (Tool PT-117 or PT-596). See configuration example below.

- S1, S2, S3 = Sockets for Fiber
- P1, P2, P3 = Pins for Fiber
- S4, S5 = Sockets for Electrical Contacts
- P4, P5 = Pins for Electrical Contacts

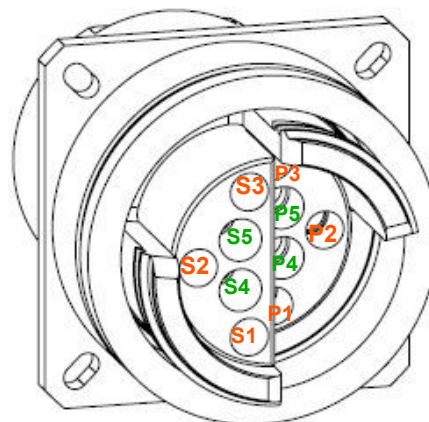

**Removing Pin, Socket or Contact** – To remove Fiber Optic Termini from the Insert cavities, use the Fiber Optic Termini Removal Tool PT-446. To remove Contacts from the Insert cavities, use the Contact Removal Tool (PT-443, PT-445 or PT-449) depending upon the size of the Contacts. Insert tool from the front and continue to compress the tool until the Fiber Optic Termini or contact ejects in the back from the retained position. (See Image Below. Plug shown for illustrative purposes.)

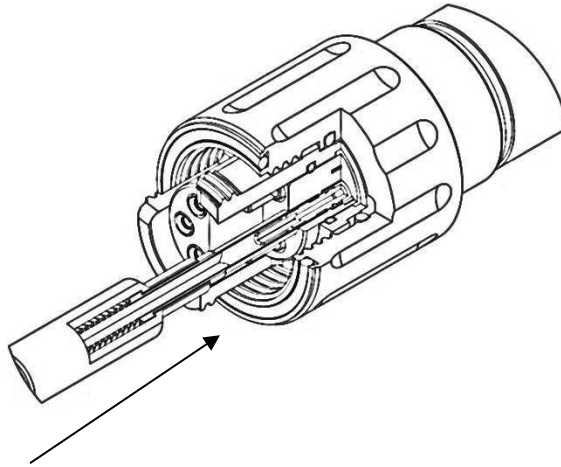

**For MT Insert** – Use MT Termini Insertion / Removal Tool PT-480 and slip Spring Push onto the prongs on the “insert” side of the tool and push MT Ferrule into the back cavity of the MT Insert. MT Ferrule should snap into place.

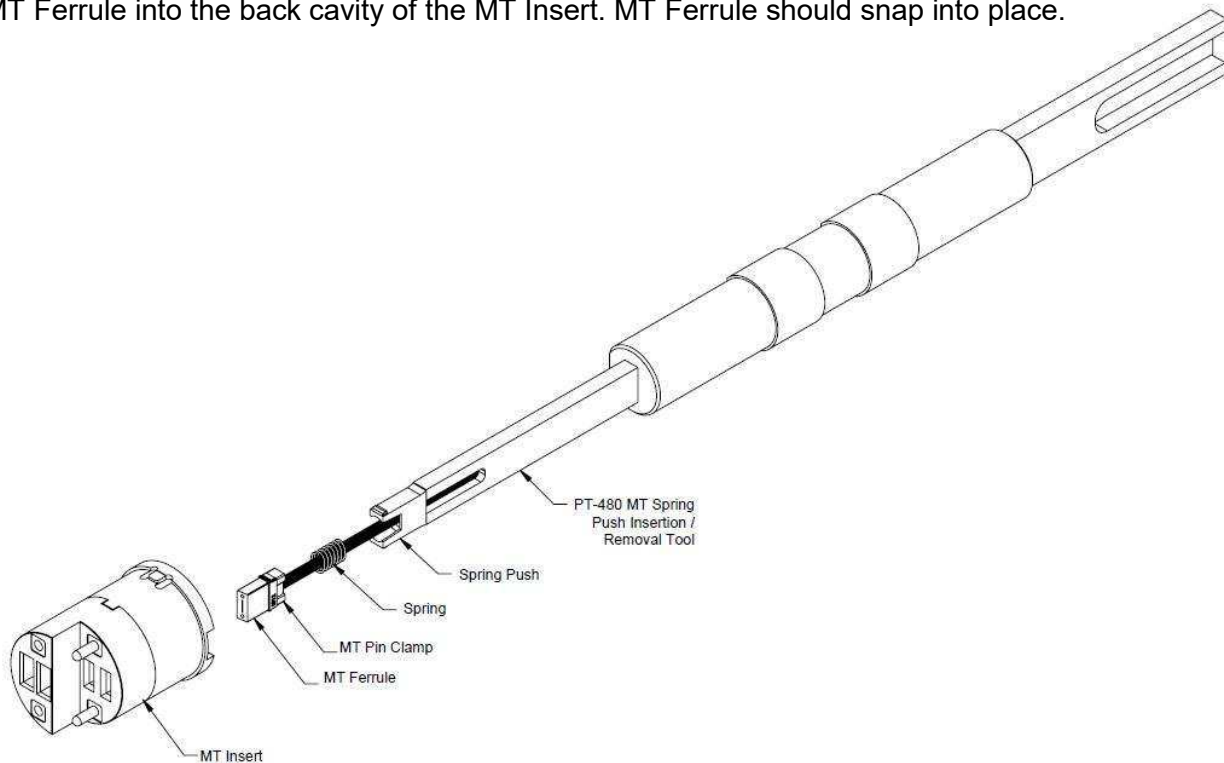



**Removing MT Ferrules** – To remove MT Ferrules from Insert cavities, unscrew the 4 screws from the back of the insert, remove Insert Cap, slide the MT Ferrule out of the way, and then use the “Remove” side of the same tool, PT-480, to push the Spring Push out. (See *Image Below*)

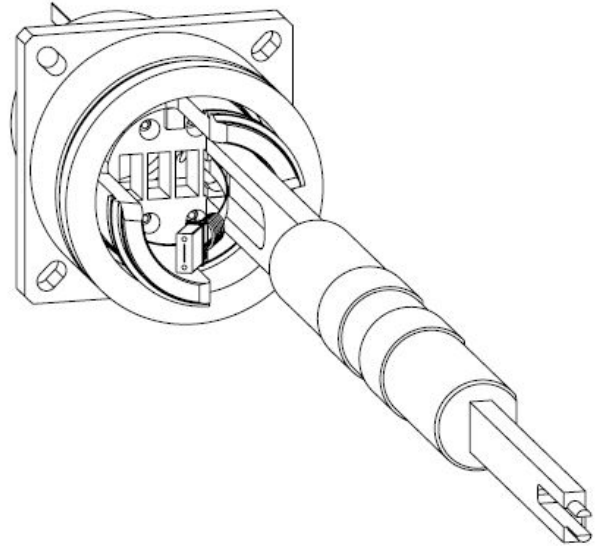

## CONNECTOR ASSEMBLY

### For Cable Options with Backshell Configurations

Slide Spacer into Body. Check the fiber length and position by looking through the holes in the Spacer to make sure the fiber is not twisted or kinked. Tighten the Set Screws at the top of the Spacer using Hex Driver PT-500. Apply Vibra-Tite VC-3 Threadmate on the threads per manufacturer’s instructions. Use Torque Hex Driver PT-590 with Hex Bit .050” PT-599 and torque Screws to the values in the above Torque Table.

Pull Strain Relief to bottom of Spacer and tighten set screws using Hex Driver PT-500. Apply Vibra-Tite VC-3 Threadmate on the threads per manufacturer’s instructions. Then use Torque Hex Driver PT-590 with Hex Bit .050” PT-599 and torque to the values in the above Torque Table.

Perform a final visual check by looking through the holes in the Spacer to make sure that the fiber is not twisted or kinked.

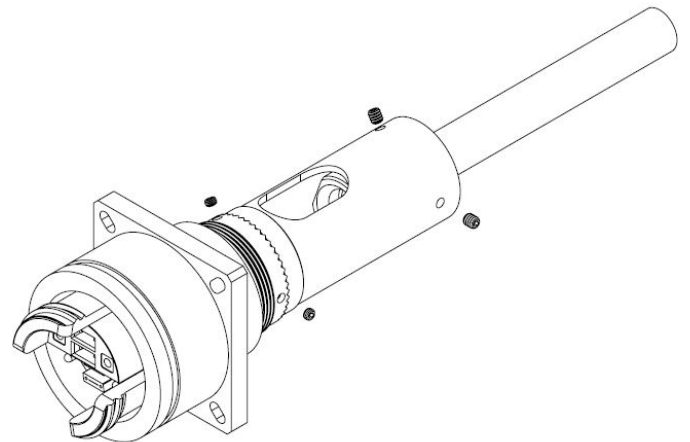

## STRAIN RELIEF ASSEMBLY

### **BOOT / BEND LIMITER OPTION:**

Secure Receptacle in a 4" Drill Press Vise PT-591. Screw Backshell Cover over Spacer. Attach the Adjustable Crow's Foot Wrench PT-536 or PT-546 onto Dial Torque-Measuring Wrench PT-506 and torque per values in Torque Table above. Slide Bend Limiter and Washer into place. Hand tighten Backnut to Backshell and torque according to the values in the above Torque Table.

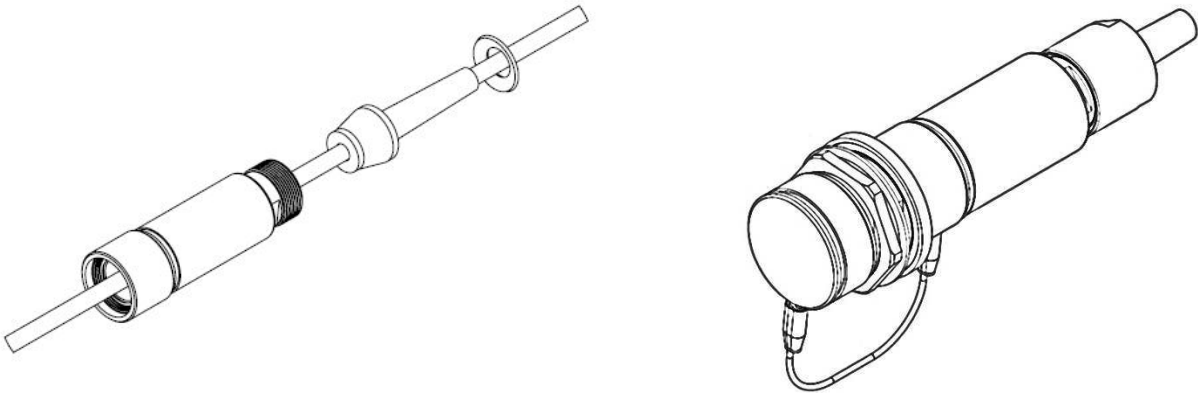

### **WIRE MESH GRIP OPTION:**

Secure Receptacle in a 4" Drill Press Vise PT-591. Screw Backshell Cover over Spacer. Attach the Adjustable Crow's Foot Wrench PT-536 or PT-546 onto Dial Torque-Measuring Wrench PT-506 and torque per values in Torque Table above. Slide the two pre-lubricated Square O-Rings and Wire Mesh Cable Grip into place. Hand tighten Backnut to Backshell and torque according to the values in the above Torque Table.

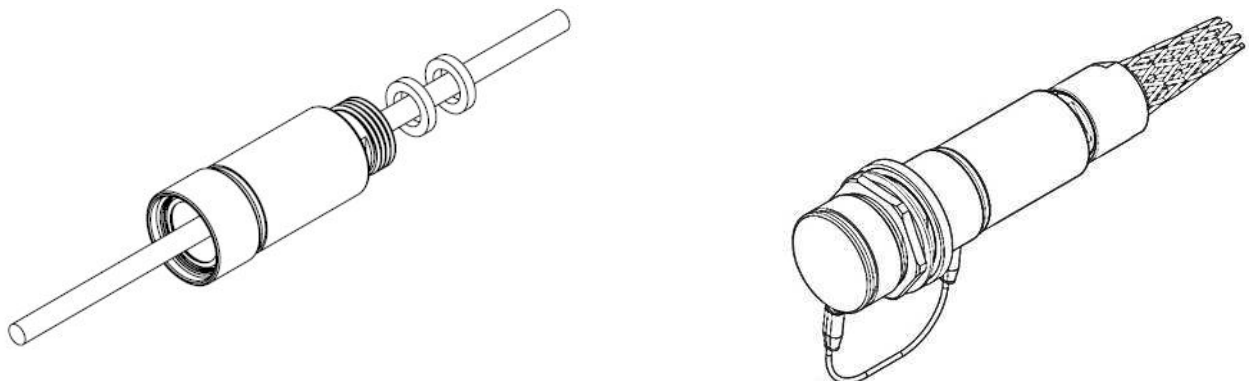

# Appendix

---

## APPENDIX A: STRIPPING LENGTHS – QLink RECEPTACLE WITH BACKSHELL ALL SIZES AND CONFIGURATIONS

D50110 – QLink THREADED AND REVERSE BAYONET PLUG or RECEPTACLE, FIBER OPTIC TERMINI  
D50111 – QLink THREADED AND REVERSE BAYONET PLUG or RECEPTACLE, HYBRID  
D50112 – QLink THREADED AND REVERSE BAYONET PLUG or RECEPTACLE, MT  
D50113 – QLink HERMAPHRODITIC PLUG or RECEPTACLE, FIBER OPTIC TERMINI  
D50114 – QLink HERMAPHRODITIC PLUG or RECEPTACLE, HYBRID  
D50115 – QLink HERMAPHRODITIC PLUG or RECEPTACLE, MT  
D50116 – QLink PUSH PULL PLUG or RECEPTACLE, FIBER OPTIC TERMINI  
D50117 – QLink PUSH PULL PLUG or RECEPTACLE, HYBRID  
D50118 – QLink PUSH PULL PLUG or RECEPTACLE, MT

## APPENDIX B: QPC FIBER OPTIC – QLink CONTACT CRIMP TOOLS / SETTINGS

# QLink THREADED AND REVERSE BAYONET PLUG or RECEPTACLE FIBER OPTIC TERMINI

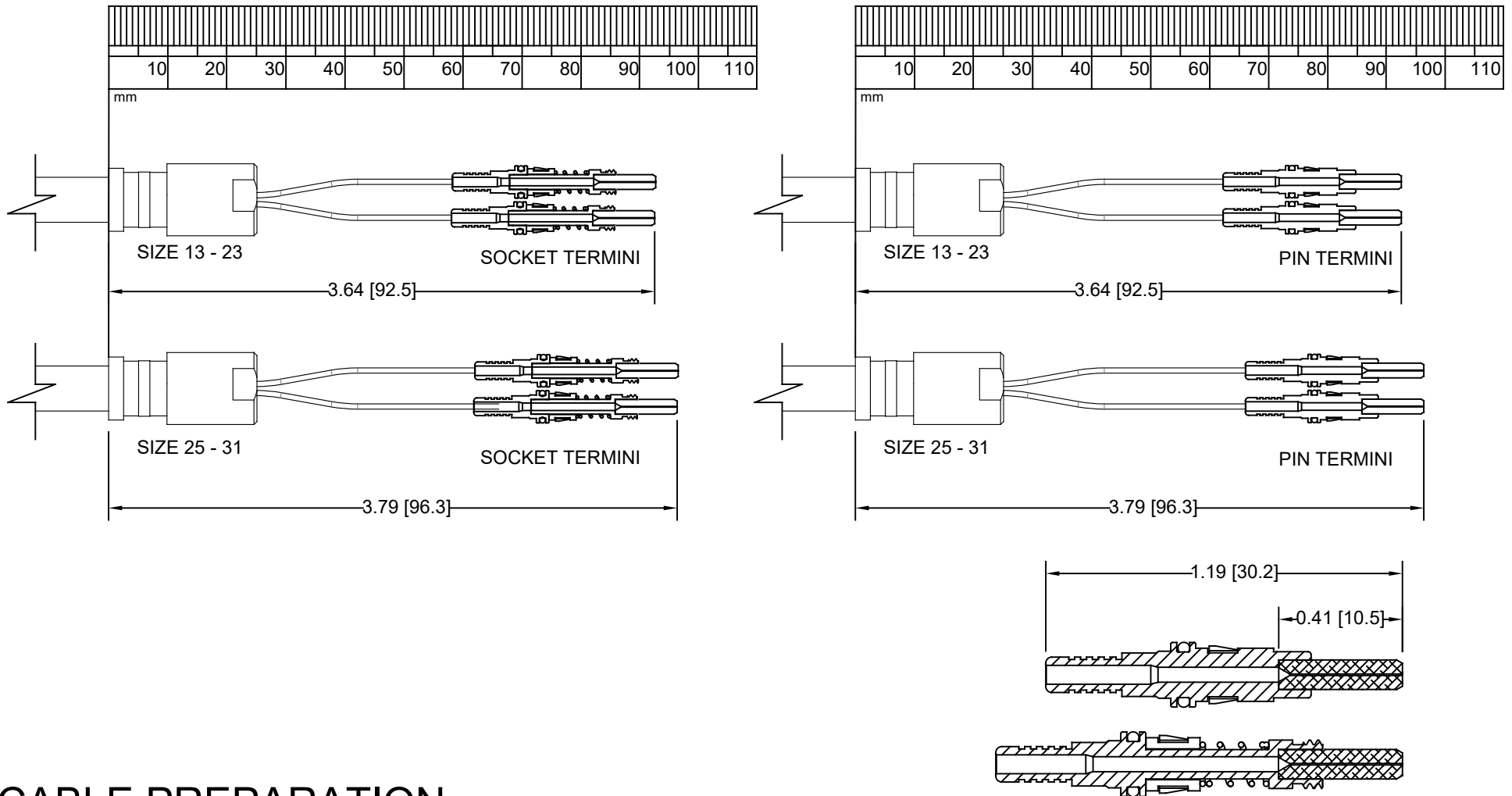

## CABLE PREPARATION

 <p><b>QPC</b> ENGINEERED FIBER OPTIC SOLUTIONS</p> <p>QPC Fiber Optic, LLC</p>	<p>PROPRIETARY AND CONFIDENTIAL THE INFORMATION CONTAINED IN THIS DRAWING IS CONFIDENTIAL AND THE SOLE PROPERTY OF QPC FIBER OPTIC. ANY REPRODUCTION IN PART OR AS A WHOLE OR DISCLOSURE OF CONTENT WITHOUT THE WRITTEN PERMISSION OF QPC FIBER OPTIC IS PROHIBITED.</p>		<p>DOC. NUMBER</p> <p><b>D50110</b></p>	<p>REV.</p> <p><b>0</b></p>			
	<p>DRAWN</p> <p><b>CWN</b></p>	<p>CHECKED</p>	<p>DIMENSIONS ARE IN INCH[MM].</p>				
	<p>DATE</p> <p><b>6/27/19</b></p>	<p>DATE</p>	<p>SHEET 1 OF 1</p>				
					<p>REV.</p>	<p>DESCRIPTION</p>	<p>DATE</p>
					<p>REVISIONS</p>		

# QLink THREADED AND REVERSE BAYONET PLUG or RECEPTACLE, HYBRID

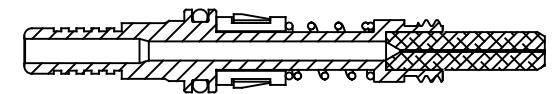
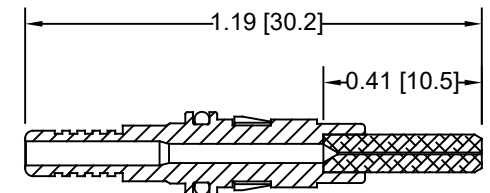
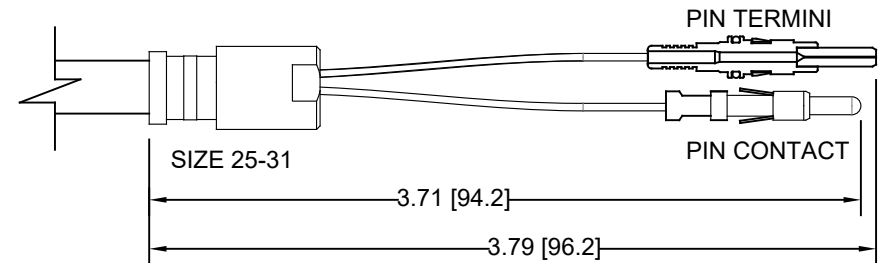
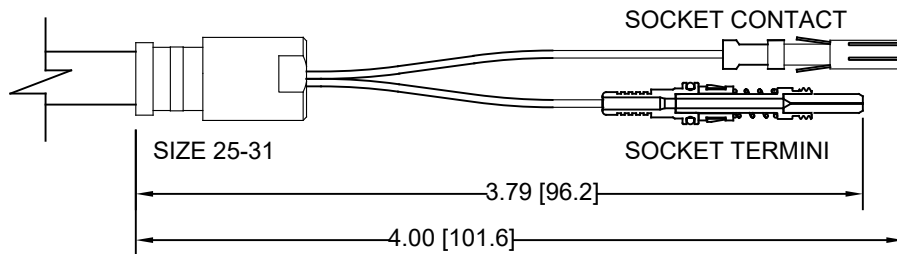
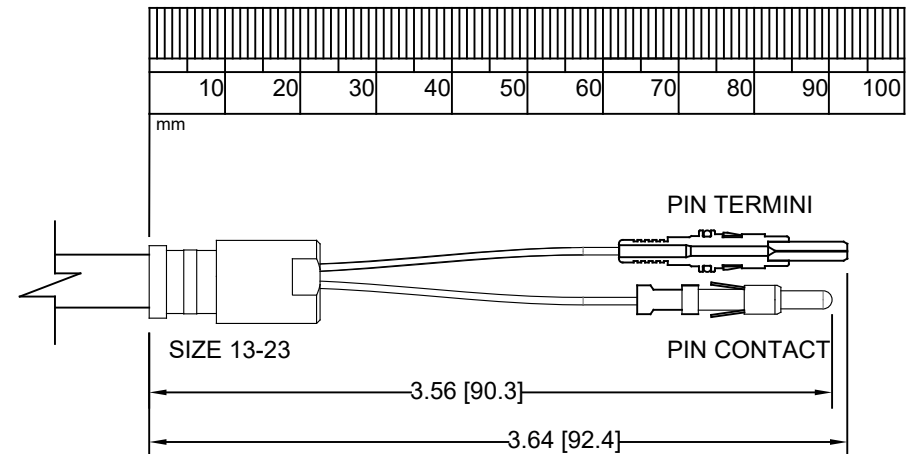
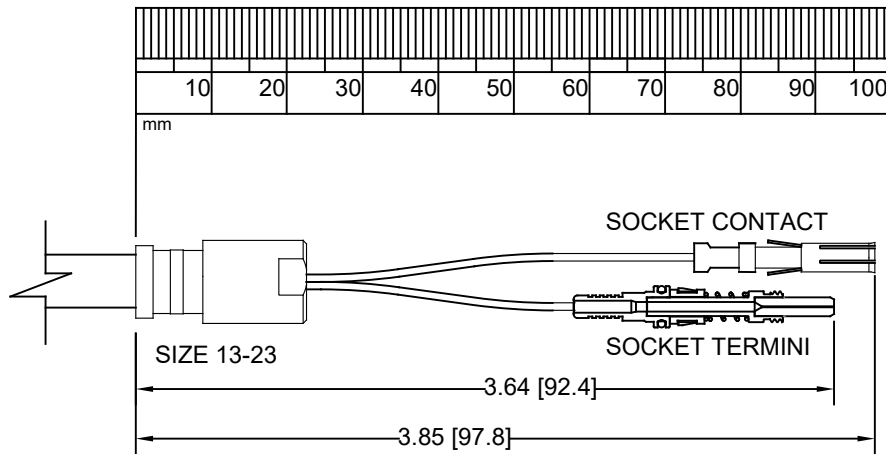

## CABLE PREPARATION

 QPC Fiber Optic, LLC <small>ENGINEERED FIBER OPTIC SOLUTIONS</small>	PROPRIETARY AND CONFIDENTIAL THE INFORMATION CONTAINED IN THIS DRAWING IS CONFIDENTIAL AND THE SOLE PROPERTY OF QPC FIBER OPTIC. ANY REPRODUCTION IN PART OR AS A WHOLE OR DISCLOSURE OF CONTENT WITHOUT THE WRITTEN PERMISSION OF QPC FIBER OPTIC IS PROHIBITED.		DOC. NUMBER <b>D50111</b>	REV. <b>0</b>
	DRAWN <b>CWN</b>	CHECKED _____	DIMENSIONS ARE IN INCH[MM].	
	DATE <b>6/27/19</b>	DATE _____	SHEET 1 OF 1	
	REV.      DESCRIPTION      DATE      APPROVED			

REV.	DESCRIPTION	DATE	APPROVED
REVISIONS			

# QLink THREADED AND REVERSE BAYONET PLUG or RECEPTACLE, MT

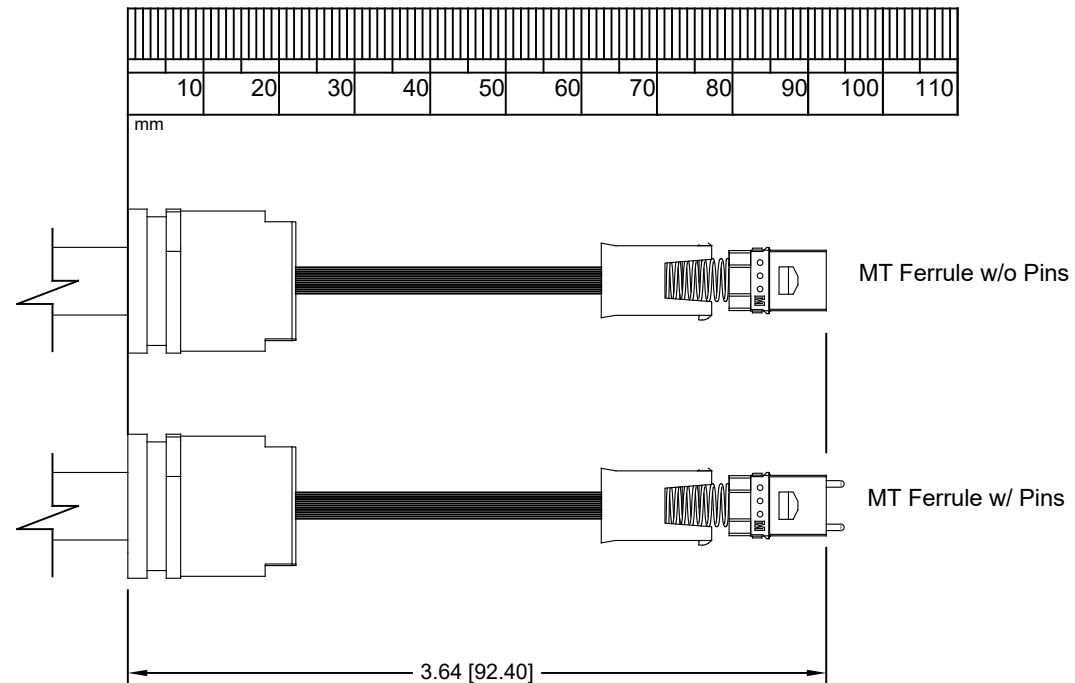

## CABLE PREPARATION



ENGINEERED FIBER OPTIC SOLUTIONS  
QPC Fiber Optic, LLC

**PROPRIETARY AND CONFIDENTIAL**  
THE INFORMATION CONTAINED IN THIS DRAWING IS CONFIDENTIAL AND THE SOLE PROPERTY OF QPC FIBER OPTIC. ANY REPRODUCTION IN PART OR AS A WHOLE OR DISCLOSURE OF CONTENT WITHOUT THE WRITTEN PERMISSION OF QPC FIBER OPTIC IS PROHIBITED.

DOC. NUMBER		REV.	
D50112		0	
DRAWN	CHECKED	DIMENSIONS ARE IN INCH[MM].	
CN			
DATE	DATE	SHEET 1 OF 1	
6/27/19			

REV.	DESCRIPTION	DATE	APPROVED
REVISIONS			

# QLink HERMAPHRODITIC PLUG or RECEPTACLE, FIBER OPTIC TERMINI

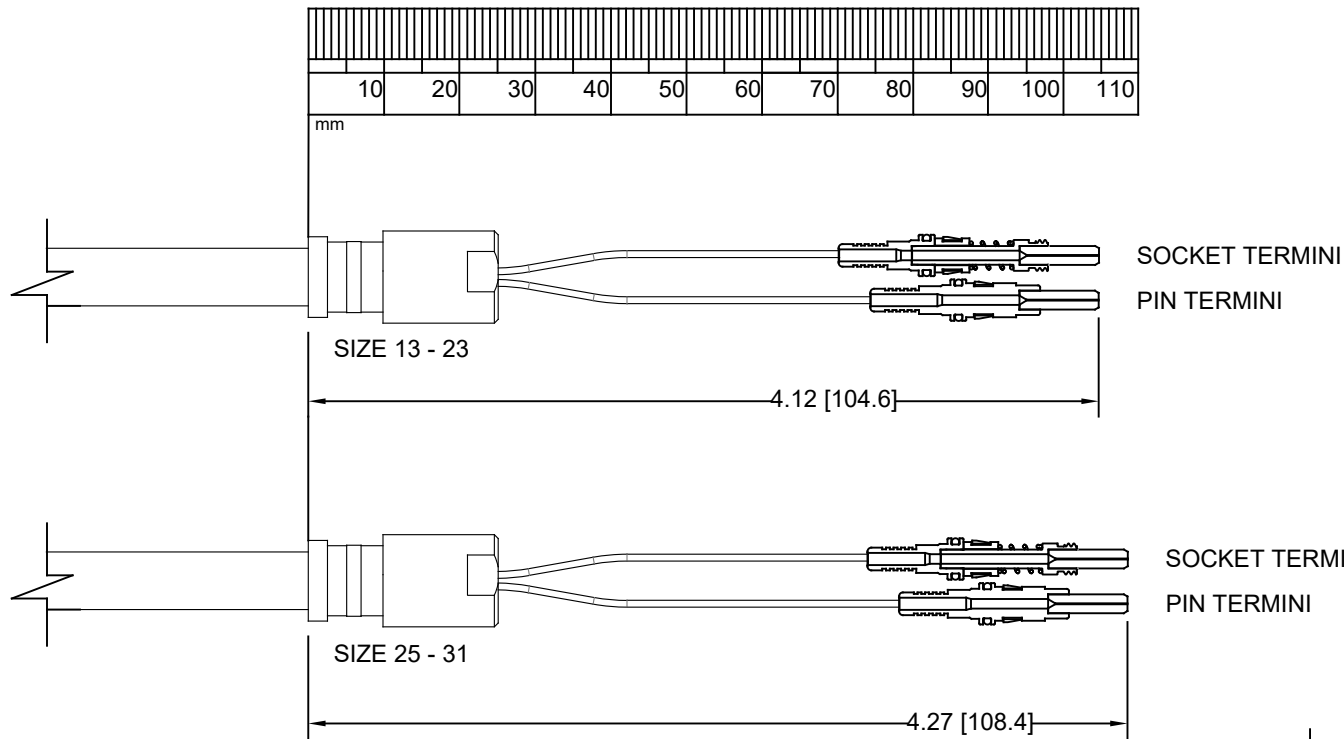

SOCKET TERMINI  
PIN TERMINI

SOCKET TERMINI  
PIN TERMINI

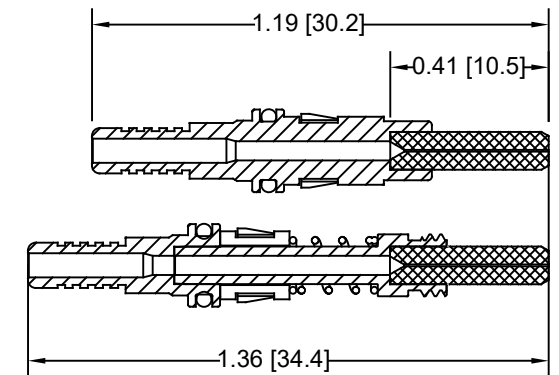

## CABLE PREPARATION



PROPRIETARY AND CONFIDENTIAL  
THE INFORMATION CONTAINED IN  
THIS DRAWING IS CONFIDENTIAL AND  
THE SOLE PROPERTY OF QPC FIBER  
OPTIC. ANY REPRODUCTION IN PART  
OR AS A WHOLE OR DISCLOSURE OF  
CONTENT WITHOUT THE WRITTEN  
PERMISSION OF QPC FIBER OPTIC IS  
PROHIBITED.

DOC. NUMBER		D50113		REV.	0
DRAWN	CHECKED	DIMENSIONS ARE IN INCH[MM].			
CWN					
DATE	DATE	SHEET 1 OF 1			
6/27/19					

REV.	DESCRIPTION	DATE	APPROVED
	REVISIONS		

# QLink HERMPHRODITIC PLUG or RECEPTACLE, HYBRID

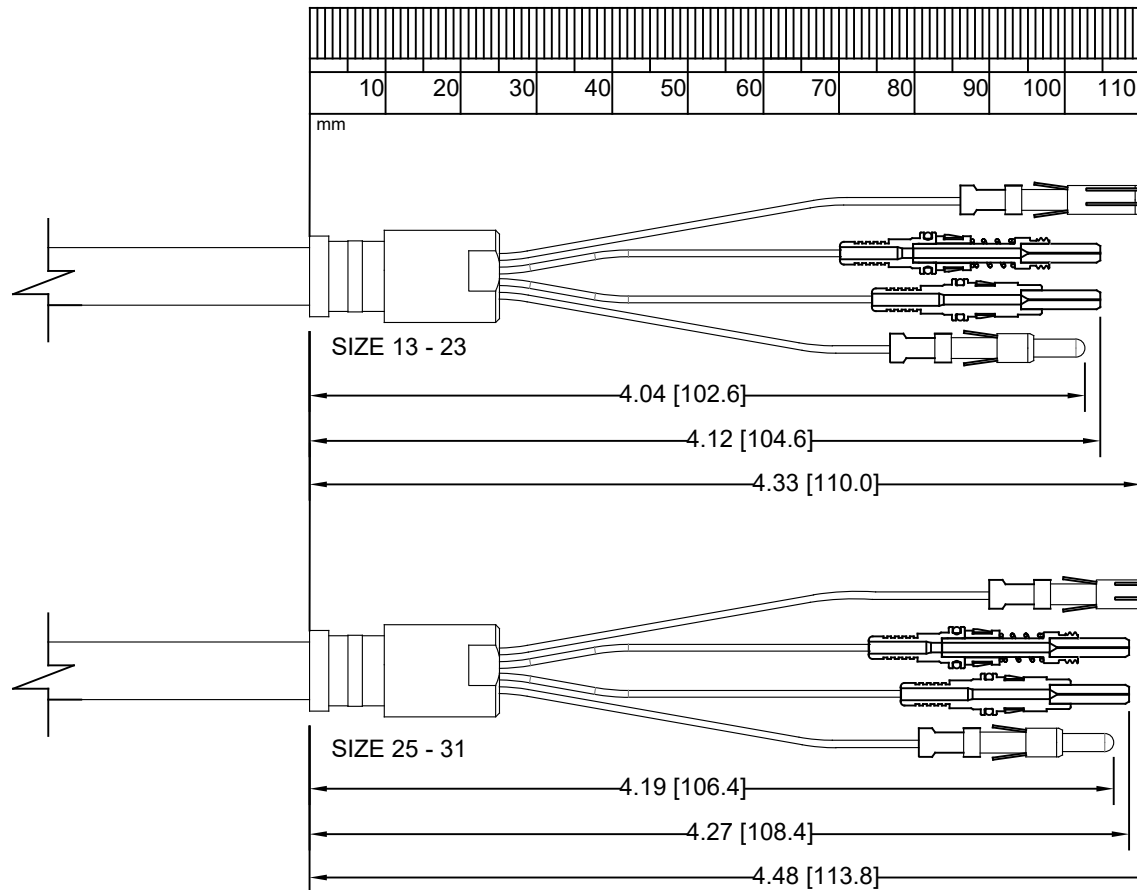

SOCKET CONTACT  
SOCKET TERMINI  
PIN TERMINI  
PIN CONTACT

SOCKET CONTACT  
SOCKET TERMINI  
PIN TERMINI  
PIN CONTACT

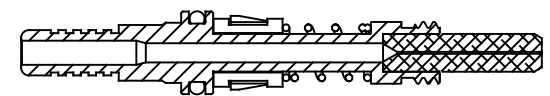
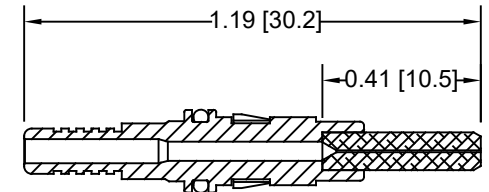

## CABLE PREPARATION



PROPRIETARY AND CONFIDENTIAL  
THE INFORMATION CONTAINED IN  
THIS DRAWING IS CONFIDENTIAL AND  
THE SOLE PROPERTY OF QPC FIBER  
OPTIC. ANY REPRODUCTION IN PART  
OR AS A WHOLE OR DISCLOSURE OF  
CONTENT WITHOUT THE WRITTEN  
PERMISSION OF QPC FIBER OPTIC IS  
PROHIBITED.

DOC. NUMBER		REV.	
D50114		0	
DRAWN	CHECKED	DIMENSIONS ARE IN INCH[MM].	
CWN			
DATE	DATE	REV.	DESCRIPTION
6/27/19			REVISIONS
SHEET 1 OF 1			

REV.	DESCRIPTION	DATE	APPROVED



# QLink HERMPHRODITIC PLUG or RECEPTACLE, MT

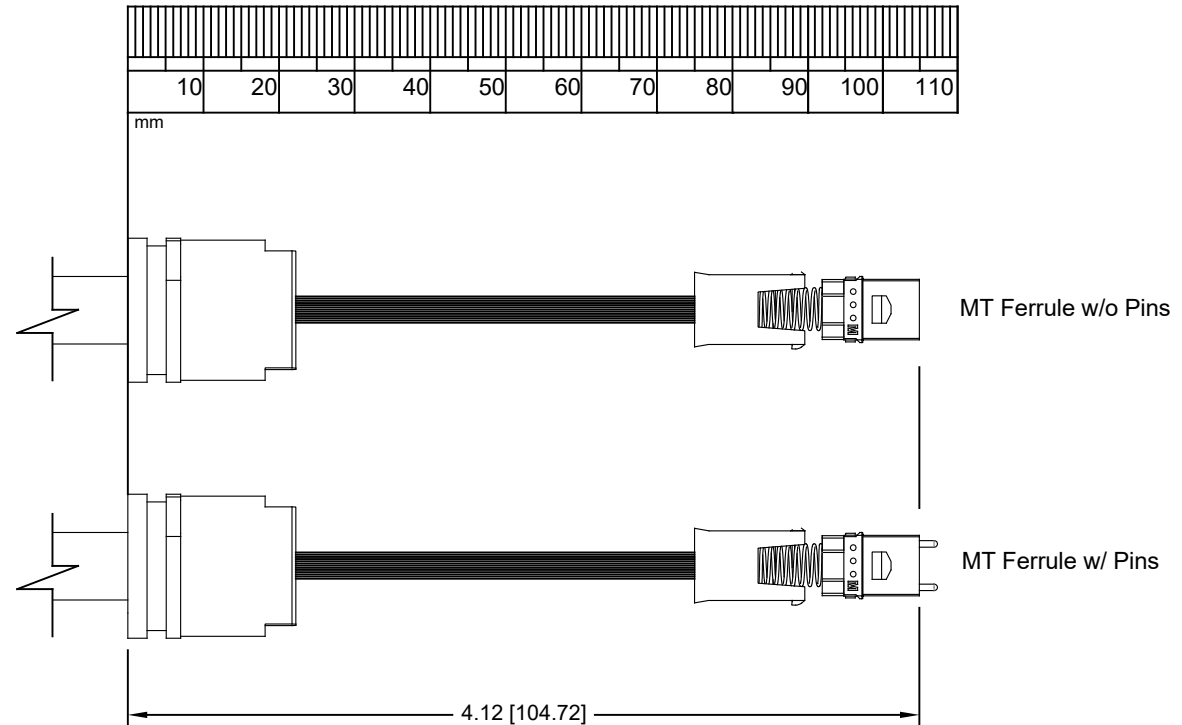

## CABLE PREPARATION



ENGINEERED FIBER OPTIC SOLUTIONS

QPC Fiber Optic, LLC

**PROPRIETARY AND CONFIDENTIAL**  
THE INFORMATION CONTAINED IN THIS DRAWING IS CONFIDENTIAL AND THE SOLE PROPERTY OF QPC FIBER OPTIC. ANY REPRODUCTION IN PART OR AS A WHOLE OR DISCLOSURE OF CONTENT WITHOUT THE WRITTEN PERMISSION OF QPC FIBER OPTIC IS PROHIBITED.

DOC. NUMBER		REV.	
D50115		0	
DRAWN	CHECKED	DIMENSIONS ARE IN INCH[MM].	
CN			
DATE	DATE	SHEET 1 OF 1	
06/27/19			

REV.	DESCRIPTION	DATE	APPROVED
REVISIONS			

# QLink PUSH PULL PLUG or RECEPTACLE FIBER OPTIC TERMINI

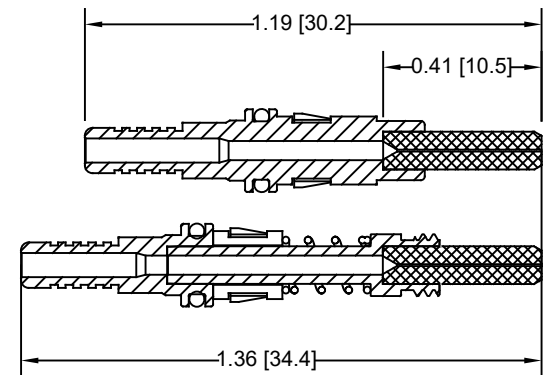
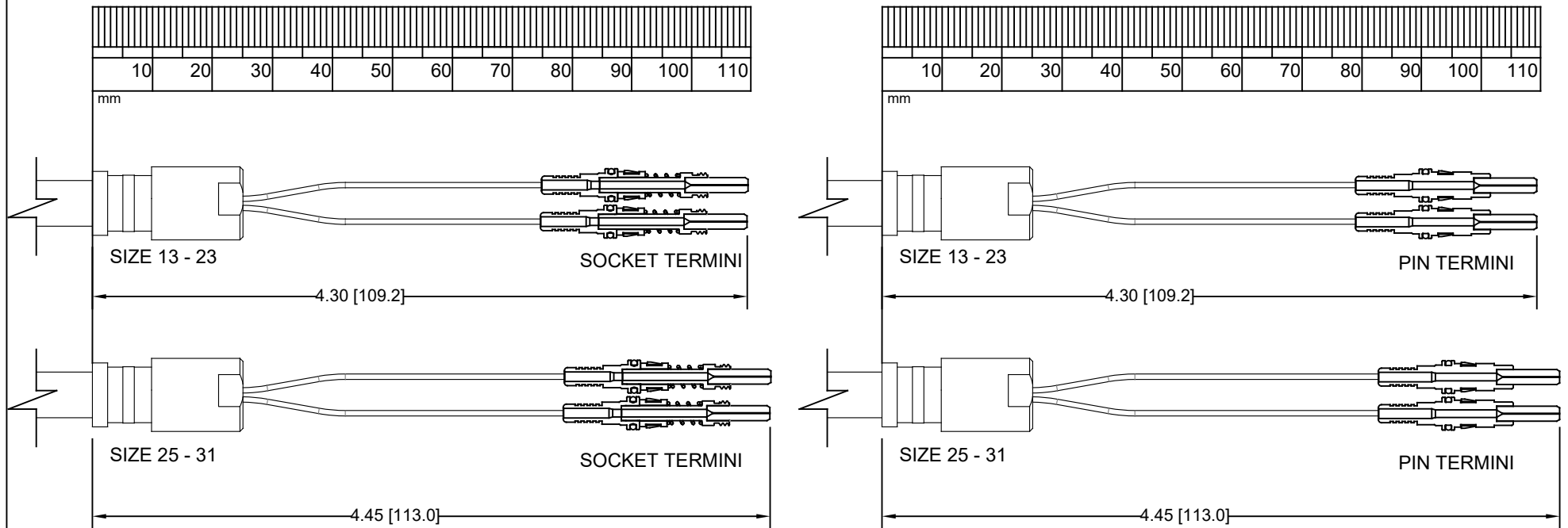

## CABLE PREPARATION

 <p><b>QPC</b> ENGINEERED FIBER OPTIC SOLUTIONS QPC Fiber Optic, LLC.</p>	<p><b>PROPRIETARY AND CONFIDENTIAL</b> THE INFORMATION CONTAINED IN THIS DRAWING IS CONFIDENTIAL AND THE SOLE PROPERTY OF QPC FIBER OPTIC. ANY REPRODUCTION IN PART OR AS A WHOLE OR DISCLOSURE OF CONTENT WITHOUT THE WRITTEN PERMISSION OF QPC FIBER OPTIC IS PROHIBITED.</p>		<p>DOC. NUMBER <b>D50116</b></p>	<p>REV. <b>0</b></p>
	<p>DRAWN <b>CN</b></p>	<p>CHECKED</p>	<p>DIMENSIONS ARE IN INCH[MM].</p>	
	<p>DATE <b>06/27/19</b></p>	<p>DATE</p>	<p>SHEET 1 OF 1</p>	
	<p>REVISIONS</p>			

REV.	DESCRIPTION	DATE	APPROVED
REVISIONS			

# QLink PUSH PULL PLUG or RECEPTACLE, HYBRID

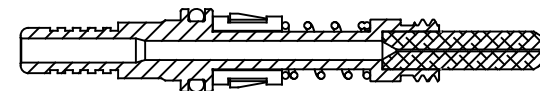
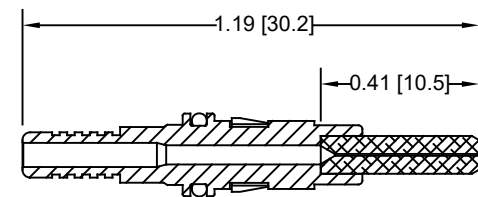
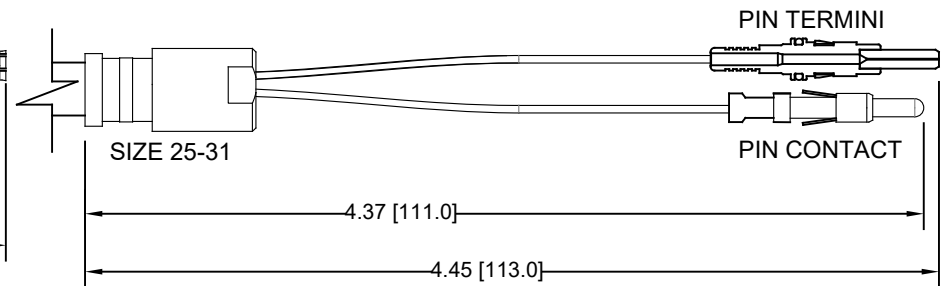
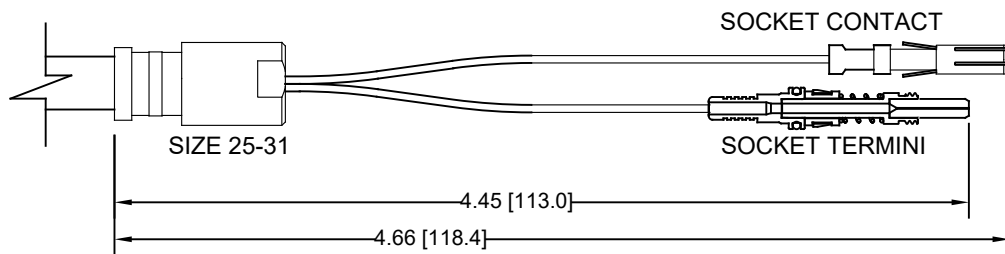
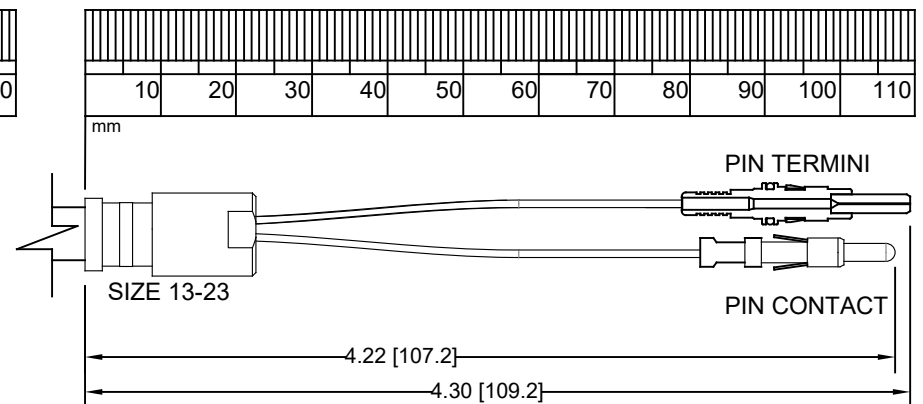
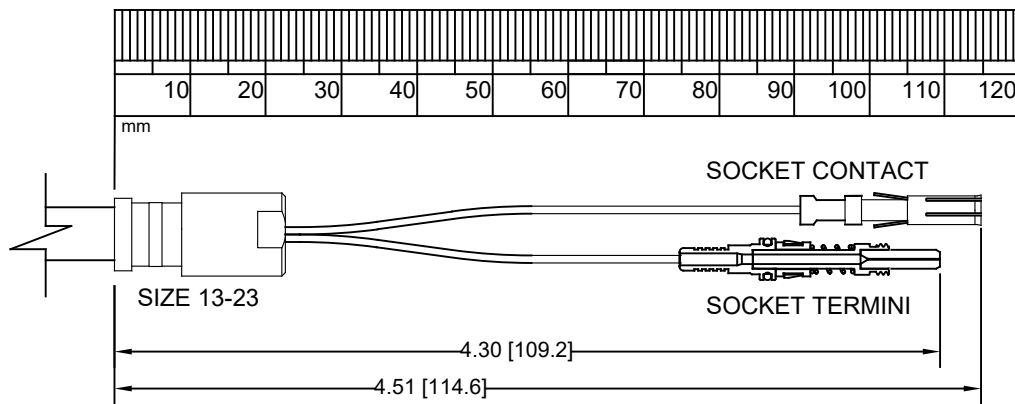

## CABLE PREPARATION



ENGINEERED FIBER OPTIC SOLUTIONS

QPC Fiber Optic, LLC

**PROPRIETARY AND CONFIDENTIAL**  
THE INFORMATION CONTAINED IN THIS DRAWING IS CONFIDENTIAL AND THE SOLE PROPERTY OF QPC FIBER OPTIC. ANY REPRODUCTION IN PART OR AS A WHOLE OR DISCLOSURE OF CONTENT WITHOUT THE WRITTEN PERMISSION OF QPC FIBER OPTIC IS PROHIBITED.

DOC. NUMBER		REV.	
D50117		0	
DRAWN	CHECKED	DIMENSIONS ARE IN INCH[MM].	
CN			
DATE	DATE		
06/27/19			
SHEET 1 OF 1			

REV.	DESCRIPTION	DATE	APPROVED
REVISIONS			

# QLink PUSH PULL PLUG or RECEPTACLE, MT

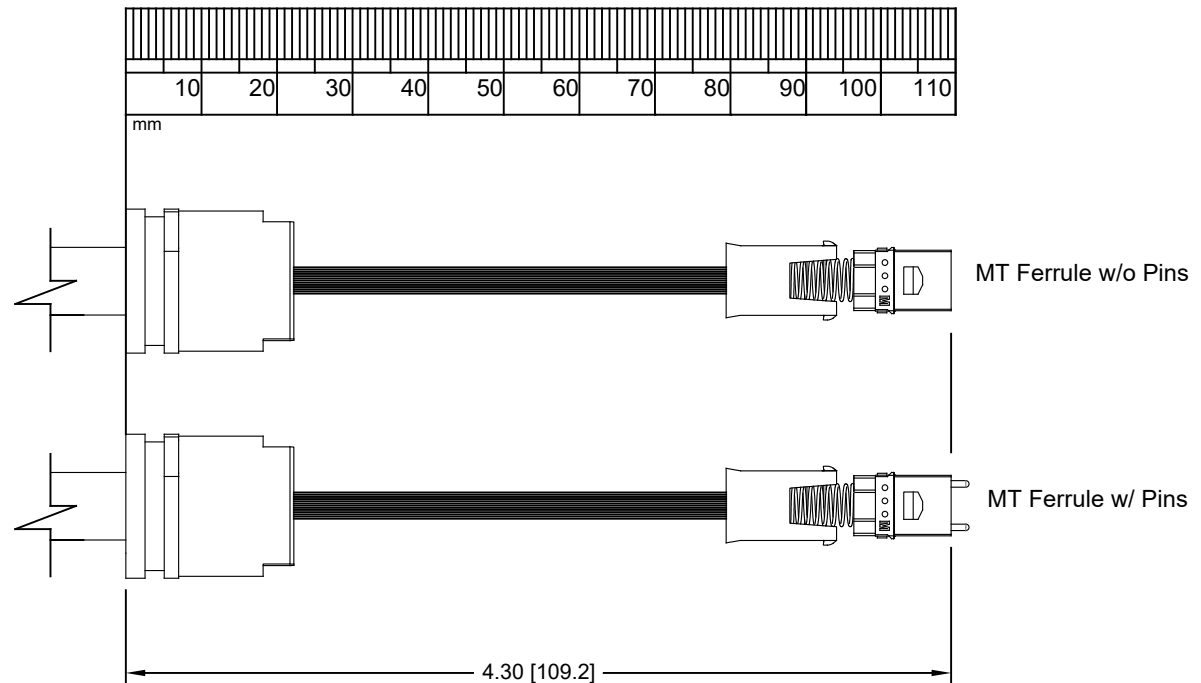

## CABLE PREPARATION



ENGINEERED FIBER OPTIC SOLUTIONS  
QPC Fiber Optic, LLC

**PROPRIETARY AND CONFIDENTIAL**  
THE INFORMATION CONTAINED IN THIS DRAWING IS CONFIDENTIAL AND THE SOLE PROPERTY OF QPC FIBER OPTIC. ANY REPRODUCTION IN PART OR AS A WHOLE OR DISCLOSURE OF CONTENT WITHOUT THE WRITTEN PERMISSION OF QPC FIBER OPTIC IS PROHIBITED.

DOC. NUMBER		REV.	
D50118		0	
DRAWN	CHECKED	DIMENSIONS ARE IN INCH[MM].	
CN			
DATE	DATE	SHEET 1 OF 1	
06/27/19			

REV.	DESCRIPTION	DATE	APPROVED
REVISIONS			

## APPENDIX B - QPC Fiber Optic - QLink Contact Crimp Tools / Settings

QPC P/N	Contact Size	Pin / Socket	Wire Size Range (AWG)	Crimp Tool	Turret / Positioner	Wire Size (AWG)	Turret Color Setting	Crimp Selector Number
QLINK-CTC-1624P	16	Pin	24-26	PT-560	PT-562	26	Blue	2
						24	Blue	3
QLINK-CTC-1624S	16	Socket	24-26	PT-560	PT-562	26	Green	2
						24	Green	3
QLINK-CTC-1620P	16	Pin	20-22	PT-560	PT-562	22	Blue	3
						20	Blue	4
QLINK-CTC-1620S	16	Socket	20-22	PT-560	PT-562	22	Green	3
						20	Green	4
QLINK-CTC-1616P	16	Pin	16-20	PT-560	PT-562	20	Blue	4
						18	Blue	5
						16	Blue	5
QLINK-CTC-1616S	16	Socket	16-20	PT-560	PT-562	20	Green	4
						18	Green	5
						16	Green	5
QLINK-CTC-1614P	16	Pin	14-16	PT-560	PT-562	16	Blue	6
						14	Blue	7
QLINK-CTC-1614S	16	Socket	14-16	PT-560	PT-562	16	Green	5
						14	Green	6
QLINK-CTC-1214P	12	Pin	14	PT-561	PT-563	14	N/A	3
QLINK-CTC-1214S	12	Socket	14	PT-561	PT-563	14	N/A	3
QLINK-CTC-1212P	12	Pin	12	PT-561	PT-563	12	N/A	3
QLINK-CTC-1212S	12	Socket	12	PT-561	PT-563	12	N/A	3
QLINK-CTC-0812P	8	Pin	12	PT-561	PT-564	12	N/A	4
QLINK-CTC-0812S	8	Socket	12	PT-561	PT-564	12	N/A	4
QLINK-CTC-0810P	8	Pin	10	PT-561	PT-564	10	N/A	5
QLINK-CTC-0810S	8	Socket	10	PT-561	PT-564	10	N/A	5
QLINK-CTC-0808P	8	Pin	8	PT-561	PT-564	8	N/A	6
QLINK-CTC-0808S	8	Socket	8	PT-561	PT-564	8	N/A	6

Note: Wire size may differ slightly by wire type / manufacturer. Crimp Selector setting may need to be adjusted (up or down) accordingly to achieve proper retention.