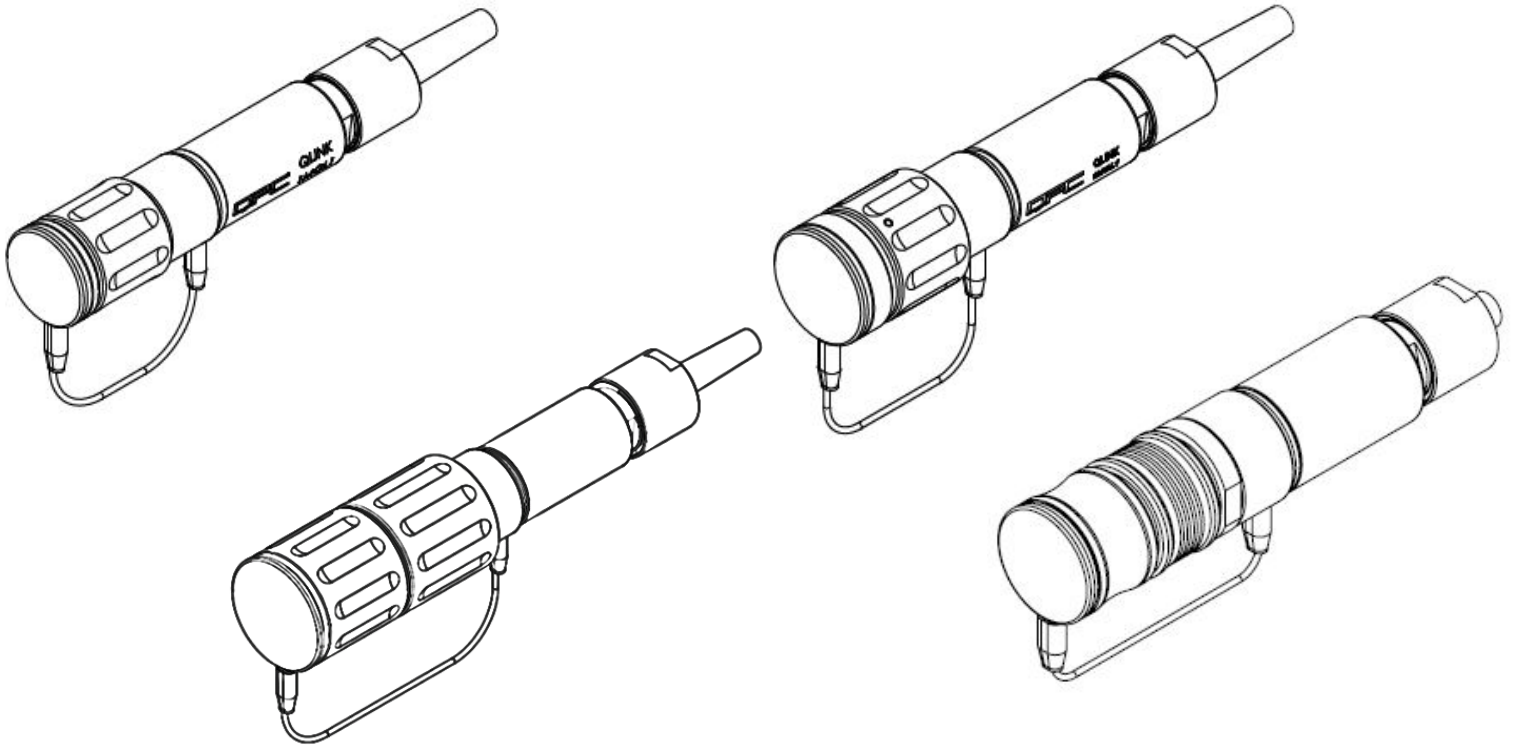


# QLink Plug Connector Customer Assembly Instructions

*Threaded / Hermaphroditic / Locking Hermaphroditic /  
Reverse Bayonet / Push Pull*



DOCUMENT:  
REVISION:  
REVISION DATE:

CAI-QLP-01  
6  
12/06/2019

**QPC CONFIDENTIAL**

**THE INFORMATION CONTAINED IN THIS DOCUMENT IS THE SOLE PROPERTY  
OF QPC FIBER OPTIC. ANY REPRODUCTION IN PART OR AS A WHOLE  
WITHOUT THE WRITTEN PERMISSION OF QPC FIBER OPTIC IS PROHIBITED.**

Document: CAI-QLP-01  
Release Date: 8/02/2018

Revision: 6  
Revision Date: 12/06/2019

QPC Fiber Optic, LLC  
27612 El Lazo Road, Laguna Niguel, CA 92677





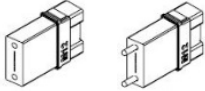
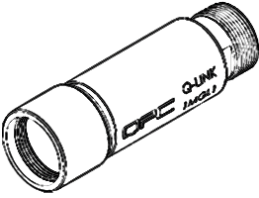
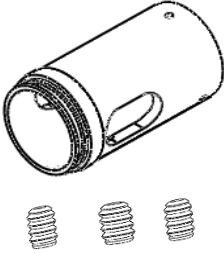


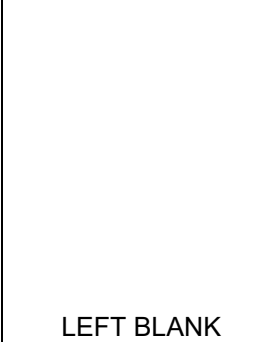
www.qpcfiber.com  
Ph: (949) 361-8855

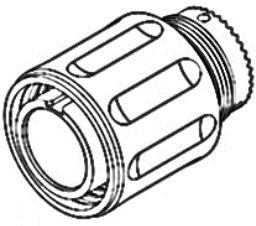



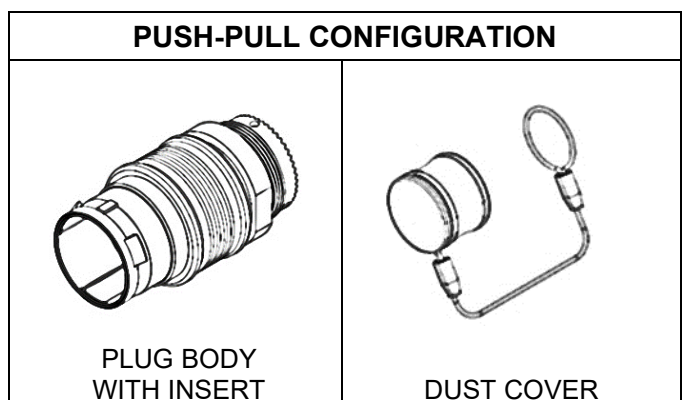
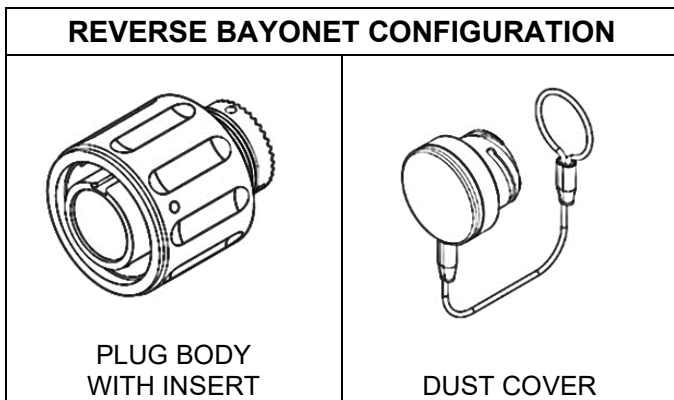
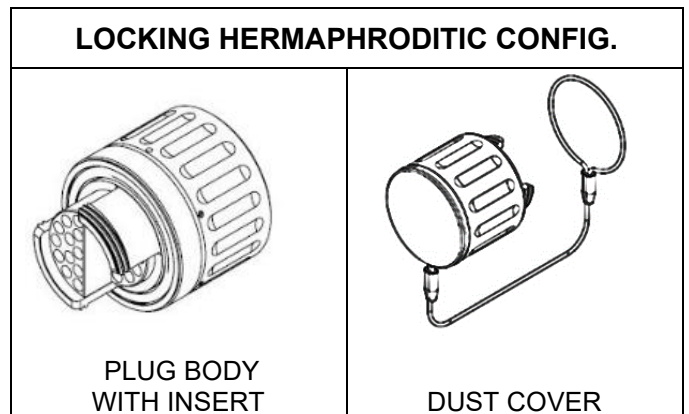
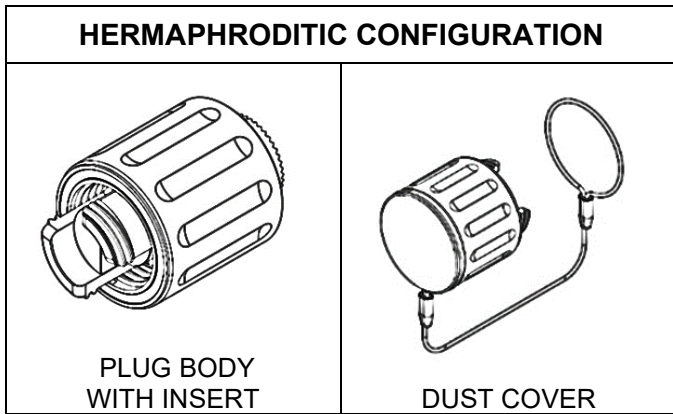
## SCOPE

This document will describe the Assembly Instructions for the QLink Plug Connector in the Threaded, Hermaphroditic, Locking Hermaphroditic, Reverse Bayonet and Push Pull configurations.

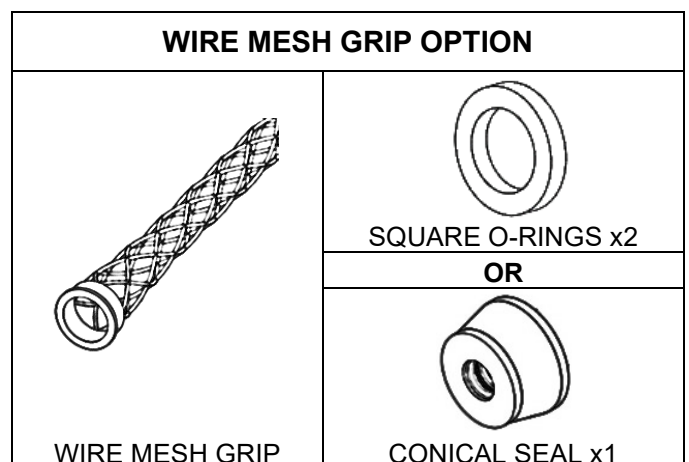
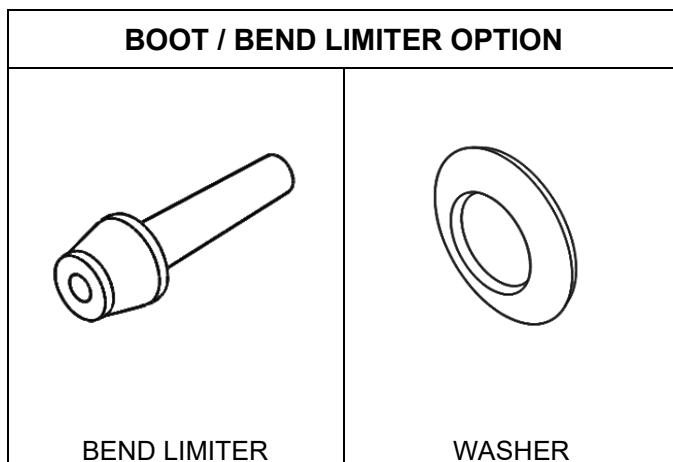
## MAIN COMPONENTS

COMMON FOR ALL CONFIGURATIONS				
				
CAP WEDGE STRAIN RELIEF	INSERT WEDGE STRAIN RELIEF	BASE WEDGE STRAIN RELIEF	FIBER OPTIC TERMINI PINS / SOCKETS	MT FERRULES (OPTIONAL)
				
BACKSHELL COVER	SPACER & 3 SET SCREWS	BACKNUT	CONTACT PIN(S) / SOCKET(S) (OPTIONAL)	LEFT BLANK

THREADED CONFIGURATION	
	
PLUG BODY WITH INSERT	DUST COVER



## STRAIN RELIEF COMPONENTS



## TOOL LIST

<b>TK-054 QPC QLink Tool Kit – (Equivalent tools may be used)</b>	
PT-117	QLink Fiber Optic Termini / Size 8 & Size 12 Contact Insertion Tool
PT-596	QLink Size 16 Contact Insertion Tool
PT-446	QLink Fiber Optic Termini Removal Tool
PT-445	QLink Size 16 Contact Removal Tool
PT-449	QLink Size 12 Contact Removal Tool
PT-443	QLink Size 8 Contact Removal Tool
PT-480	MT Fiber Optic Termini Insertion / Removal Tool
PT-005	Fiber Optic Termini Crimp Tool, 2mm, 3mm (Hex Sizes .100 / .147)
PT-560	Standard Adjustable Indent Crimp Tool M22520/1-01, Size 16 Contact
PT-562	Turret Head, Size 16, Pin and Socket, 26-14 AWG (Use with PT-560)
PT-561	Adjustable Hand Crimp Tool, Size 8 & Size 12 Contact
PT-563	Single Position Head, Size 12, Pin and Socket, 14-12 AWG (Use with PT-561)
PT-564	Single Position Head, Size 8, Pin and Socket, 12-8 AWG (Use with PT-561)
PT-589	Socket Fiber Optic Termini Sleeve Retainer Torque Tool

<b>TK-060 QPC Cable and Connector Prep Tool Kit – (Equivalent tools may be used)</b>	
PT-062	Miller Kevlar Scissors (Carbon Molybdenum & Vanadium Steel Blade)
PT-500	Precise-Control .050" Screwdriver (1.27mm) Hex
PT-501	Precise-Control Screwdriver, 1/16" Hex
PT-503	Precise-Control Screwdriver, 5/64" (2mm) Hex
PT-502	Precise-Control Screwdriver, 3/32" Hex
PT-504	Precise-Control Screwdriver, 2.5mm Hex
PT-505	Screwdriver, Number 1 Phillips, 6-3/4" Overall Length
PT-506	Dial Torque-Measuring Wrench, 3/8" Square Drive, 0 to 150in.-lbs. and 0 to 18NM Torque
PT-536	Crow's Foot Wrench Adjustable 3/8" Square Drive 0.0-1.125"(0-28.57mm) (For Shell Sizes 13 – 19)
PT-545	Crow's Foot Wrench Adjustable 1/2" Square Drive .236-1.771" (6-45mm) (For Shell Sizes 21 – 31)
PT-546	3/8" Female x 1/2" Male Square Drive Adapter, Chrome
PT-532	Long-Nose Pliers with Flat Jaws, Cushion Grip, 6-3/4" Overall, Manual Jaws with Wire Cutter
PT-599	Hex Bit Set, 5 pcs (.050", 1/16", 5/64", 3/32", 2.5mm) 1/4" Shank, Overall Length 2"
PT-590	Torque-Measuring Screwdriver, Hex Drive, 2.5 to 11.5 in.-lbs. Adjustable Torque
PT-591	4" Drill Press Vise with 2 x Machined Plastic Jaws with Groove

## TOOL LIST – Torque Fixtures

QLink Torque Fixtures (Sizes 13, 15, 17, 19, 21)	
PT-601	Torque Fixture, Plate Size 13, 15, 17, 19, 21
PT-600-13-T	Torque Fixture, QLink, Size 13, Threaded
PT-600-13-H	Torque Fixture, QLink, Size 13, Hermaphroditic
PT-600-13-RB	Torque Fixture, QLink, Size 13, Reverse Bayonet
PT-600-15-T	Torque Fixture, QLink, Size 15, Threaded
PT-600-15-H	Torque Fixture, QLink, Size 15, Hermaphroditic
PT-600-15-RB	Torque Fixture, QLink, Size 15, Reverse Bayonet
PT-600-17-T	Torque Fixture, QLink, Size 17, Threaded
PT-600-17-H	Torque Fixture, QLink, Size 17, Hermaphroditic
PT-600-17-RB	Torque Fixture, QLink, Size 17, Reverse Bayonet
PT-600-19-T	Torque Fixture, QLink, Size 19, Threaded
PT-600-19-H	Torque Fixture, QLink, Size 19, Hermaphroditic
PT-600-19-RB	Torque Fixture, QLink, Size 19, Reverse Bayonet
PT-600-21-T	Torque Fixture, QLink, Size 21, Threaded
PT-600-21-H	Torque Fixture, QLink, Size 21, Hermaphroditic
PT-600-21-RB	Torque Fixture, QLink, Size 21, Reverse Bayonet

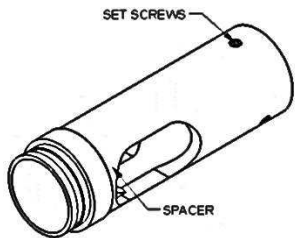
QLink Torque Fixtures (Sizes 23, 25, 27, 29, 31)	
PT-602	Torque Fixture, Plate Size 23, 25, 27, 29, 31
PT-600-23-T	Torque Fixture, QLink, Size 23, Threaded
PT-600-23-H	Torque Fixture, QLink, Size 23, Hermaphroditic
PT-600-23-RB	Torque Fixture, QLink, Size 23, Reverse Bayonet
PT-600-25-T	Torque Fixture, QLink, Size 25, Threaded
PT-600-25-H	Torque Fixture, QLink, Size 25, Hermaphroditic
PT-600-25-RB	Torque Fixture, QLink, Size 25, Reverse Bayonet
PT-600-27-T	Torque Fixture, QLink, Size 27, Threaded
PT-600-27-H	Torque Fixture, QLink, Size 27, Hermaphroditic
PT-600-27-RB	Torque Fixture, QLink, Size 27, Reverse Bayonet
PT-600-29-T	Torque Fixture, QLink, Size 29, Threaded
PT-600-29-H	Torque Fixture, QLink, Size 29, Hermaphroditic
PT-600-29-RB	Torque Fixture, QLink, Size 29, Reverse Bayonet
PT-600-31-T	Torque Fixture, QLink, Size 31, Threaded
PT-600-31-H	Torque Fixture, QLink, Size 31, Hermaphroditic
PT-600-31-RB	Torque Fixture, QLink, Size 31, Reverse Bayonet

## TORQUE TABLE

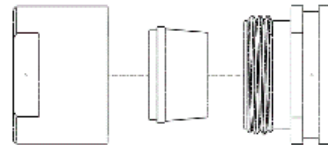
Component	Backshell / Backnut				Strain Relief	Set Screws	Sleeve Retainer
Shell Size	13 – 15	17 – 19	21 – 23	25 – 31	All	All	All
Torque Values	80 – 97 in-lb	89 – 106 in-lb	106 – 124 in-lb	124 – 141 in-lb	80 – 97 in-lb	5 – 6 in-lb	2 – 3 in-lb
	9 – 11 N • m	10 – 12 N • m	12 – 14 N • m	14 – 16 N • m	9 – 11 N • m	.56 – .68 N • m	.23 – .34 N • m

## CONNECTOR PREPARATION

Unscrew Backnut from Backshell Cover.  
Unscrew Backshell Cover from Plug Body.  
Use Hex Driver PT-500 to loosen set screws from Spacer.



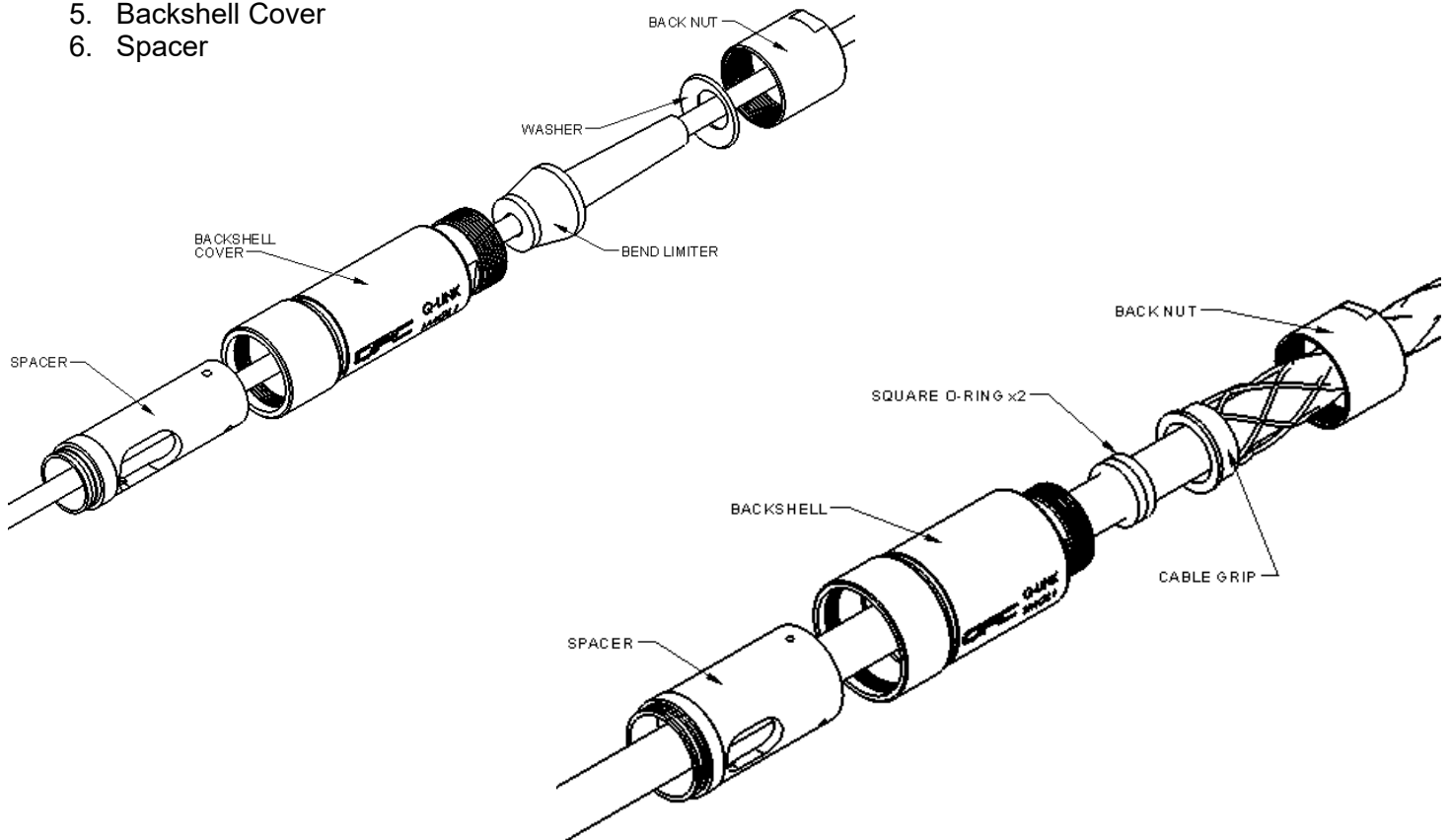
Remove Cap, Insert, and Base of Wedge Strain Relief from bag.



## CABLE PREPARATION

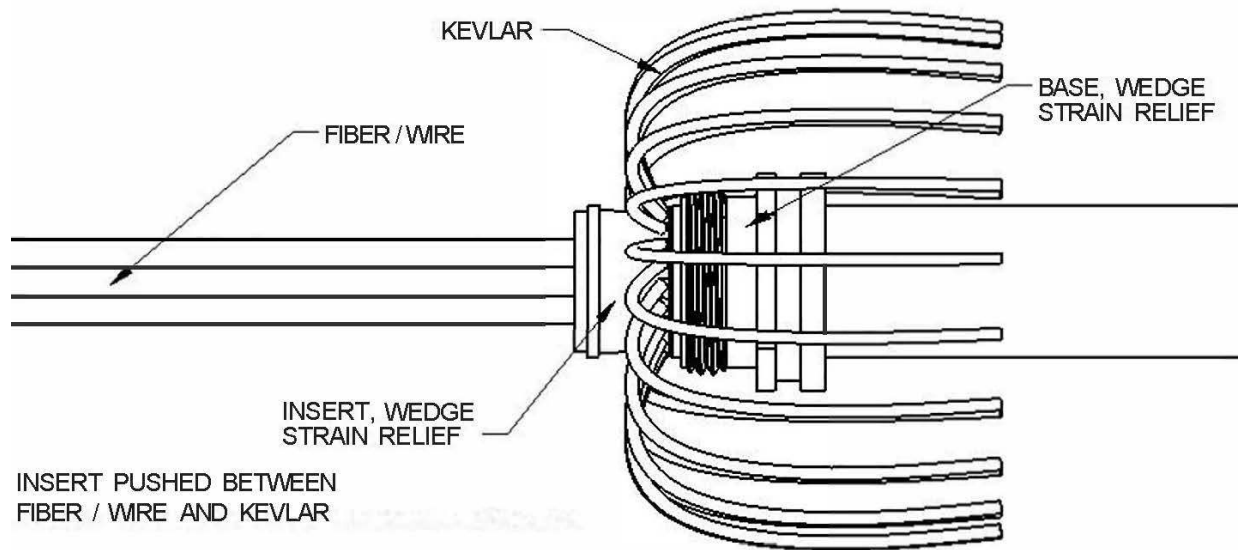
Slide parts over cable in the following order:

1. Label (if applicable)
2. Backnut
3. Cable Grip OR Washer
4. Square O-Ring (x 2) OR Bend Limiter
5. Backshell Cover
6. Spacer

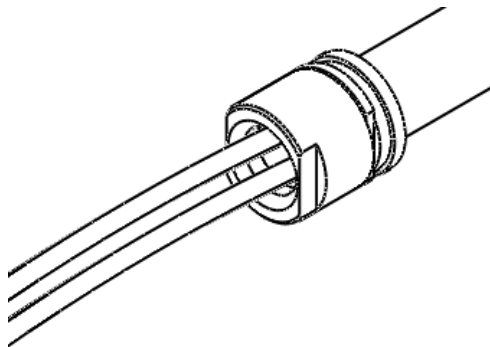


Strip cable jacket 6" from end. Separate Kevlar and remove any additional cable elements with Kevlar Scissors PT-062.

Slide base of wedge strain relief back to jacket edge. Slide Insert of wedge strain relief inside base and push between the Kevlar and the individual fibers / wires.



Cut Kevlar flush with top of wedge. Screw on Cap of Wedge Strain Relief. Torque to tighten using values from Torque Table above.

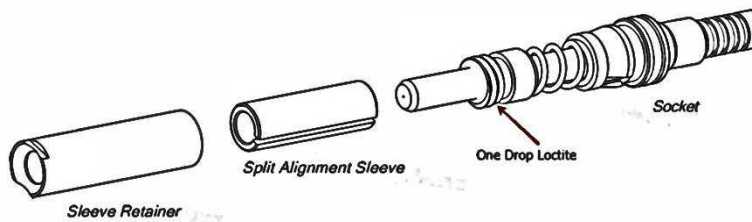




## TERMINATE

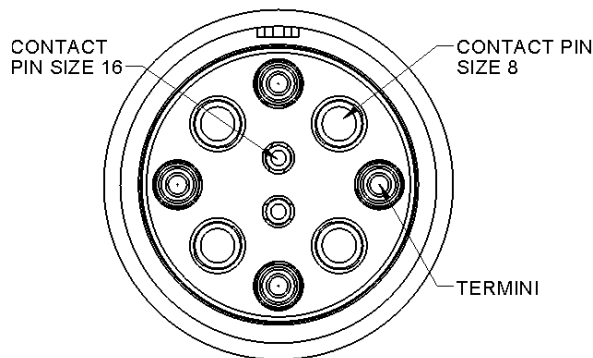
Use the Stripping Length Diagrams in the Appendix located in the back of this Assembly Instruction for the desired connector configuration to Terminate and polish the fiber and install the Electrical Contacts using the provided Fiber Optic Termini / Contacts. For Fiber Optic / Wire Termination and Polishing details, reference CAI-TERM-02.

Note: After Polishing Sockets, slide the Split Alignment Sleeve over the Fiber Optic Termini and then slide the Sleeve Retainer over the Split Alignment Sleeve to the base of the Fiber Optic Termini. Apply a drop of VC-3 Threadmate and screw the Sleeve Retainer onto the thread of the Fiber Optic Termini. Torque using the Sleeve Retainer Torque Tool PT-589 to the torque values in the table above.

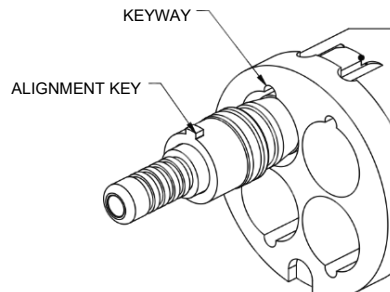


## POPULATE INSERT

Use appropriate Insertion (Tool PT-117 or PT-596) to insert Fiber Optic Termini or Contacts according to the desired pinout (varies by connector size and channel count). Image below shows a hybrid insert.



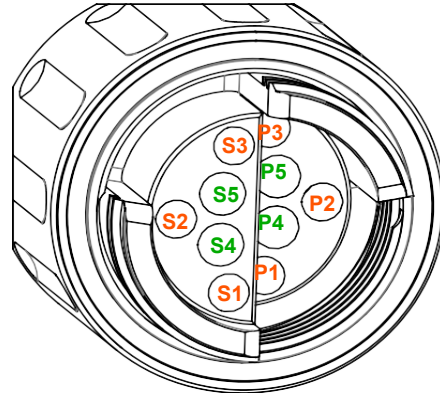
When populating using APC Fiber Optic Termini, align the key on the Fiber Optic Termini with keyway in the Insert.



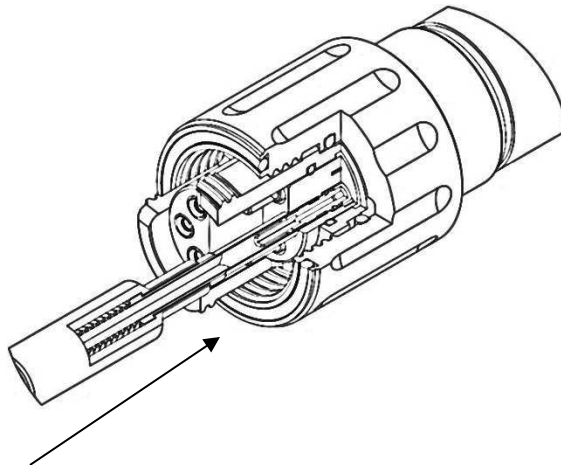


**For Hermaphroditic Insert** – Push in Fiber Optic Termini / Contact Pin and Sockets through back of Insert using appropriate Insertion (Tool PT-117 or PT-596). See configuration example below.

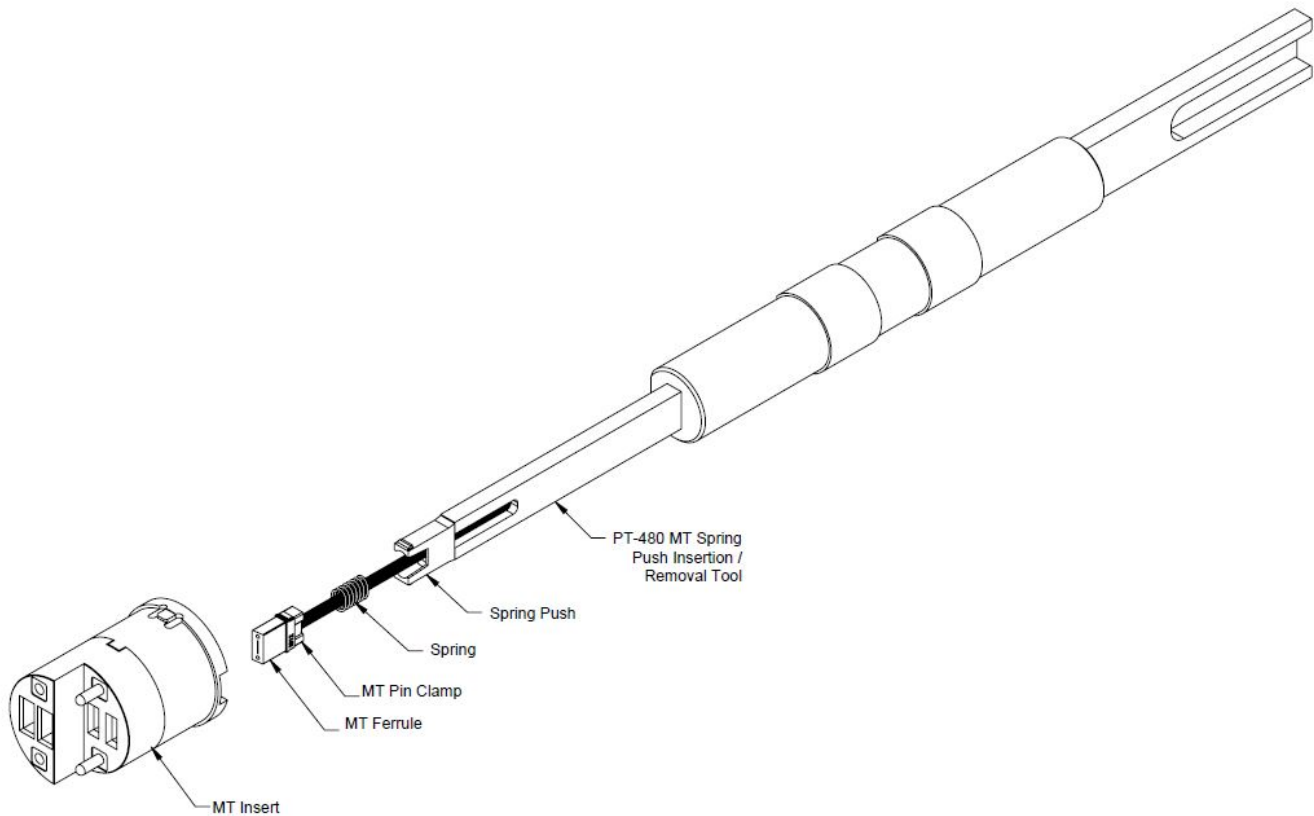
- S1, S2, S3 = Sockets for Fiber
- P1, P2, P3 = Pins for Fiber
- S4, S5 = Sockets for Electrical Contacts
- P4, P5 = Pins for Electrical Contacts



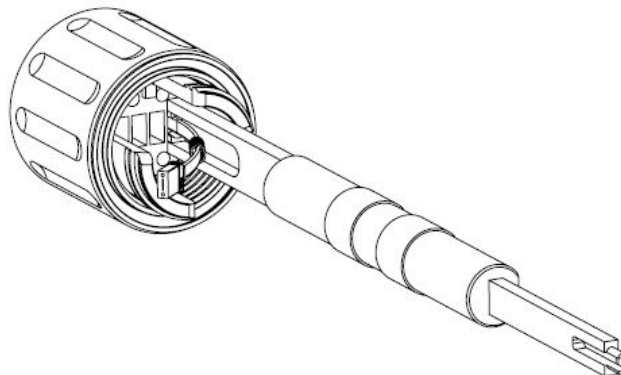
**Removing Pin, Socket or Contact** – To remove Fiber Optic Termini from the Insert cavities, use the Fiber Optic Termini Removal Tool PT-446. To remove Contacts from the Insert cavities, use the Contact Removal Tool (PT-443, PT-445 or PT-449) depending upon the size of the Contacts. Insert tool from the front and continue to compress the tool until the Fiber Optic Termini or contact ejects in the back from the retained position. (See Image Below)



**For MT Insert** – Use MT Termini Insertion / Removal Tool PT-480 and slip Spring Push onto the prongs on the “insert” side of the tool and push MT Ferrule into the back cavity of the MT Insert. MT Ferrule should snap into place.

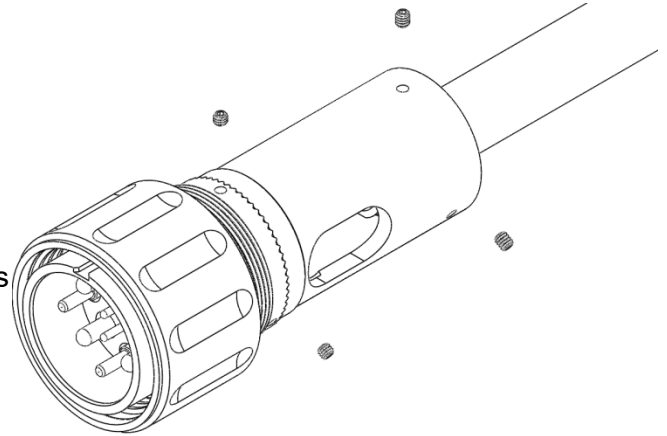


**Removing MT Ferrules** – To remove MT Ferrules from Insert cavities, unscrew the 4 screws from the back of the insert, remove Insert Cap, slide the MT Ferrule out of the way, and then use the “Remove” side of the same tool, PT-480, to push the Spring Push out. (See *Image Below*)



## CONNECTOR ASSEMBLY

Slide Spacer into Body. Check the fiber length and position by looking through the holes in the Spacer to make sure the fiber is not twisted or kinked. Tighten set screws using Hex Driver PT-500. A drop of VC-3 Threadmate may be used. Then use Torque Hex Driver PT-590 with Hex Bit .050" PT-599 and Torque to the values in the above Torque Table.



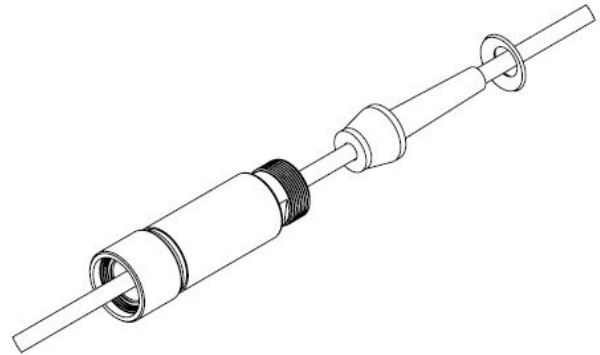
Pull Strain Relief to bottom of spacer and tighten set screws using Hex Driver PT-500. A drop of VC-3 Threadmate may be used. Then use Torque Hex Driver PT-590 with Hex Bit .050" PT-599 and Torque to the values in the above Torque Table.

Perform a final visual check by looking through the holes in the Spacer to make sure that the fiber is not twisted or kinked.

## STRAIN RELIEF ASSEMBLY

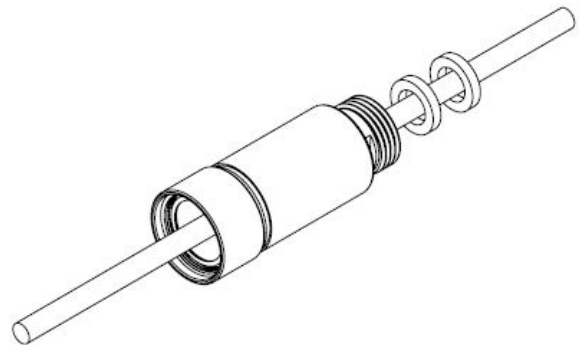
### BOOT / BEND LIMITER OPTION:

Screw Backshell Cover over Spacer. Slide Bend Limiter into place, then Washer flush with Backshell Cover.



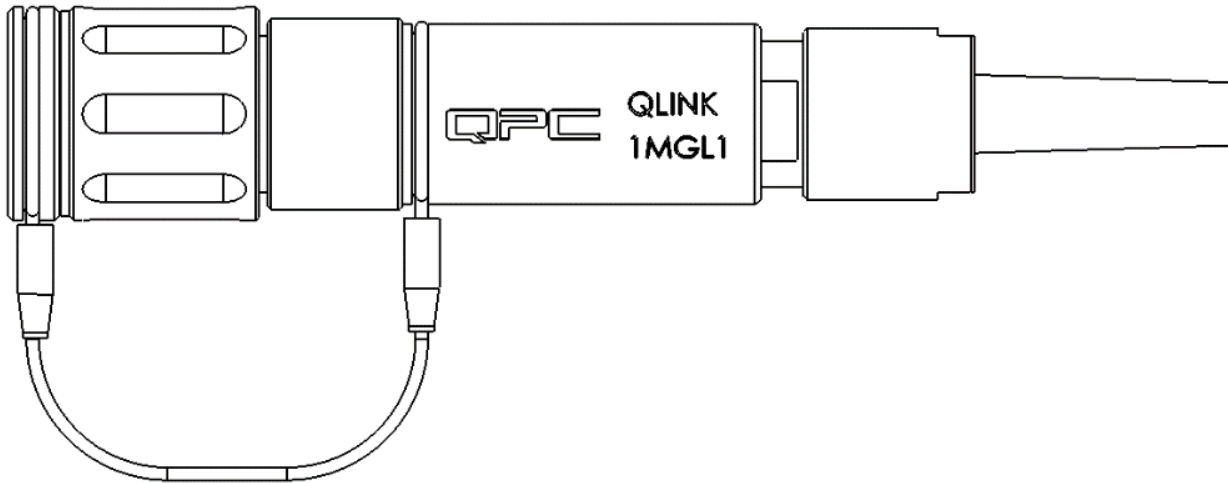
### WIRE MESH GRIP OPTION:

Screw Backshell Cover onto Plug Body. Slide 2 Square O-Rings into place. All O-Rings are pre-lubricated. Use extra O-Ring lubricant if desired. Slide Cable Grip into place.

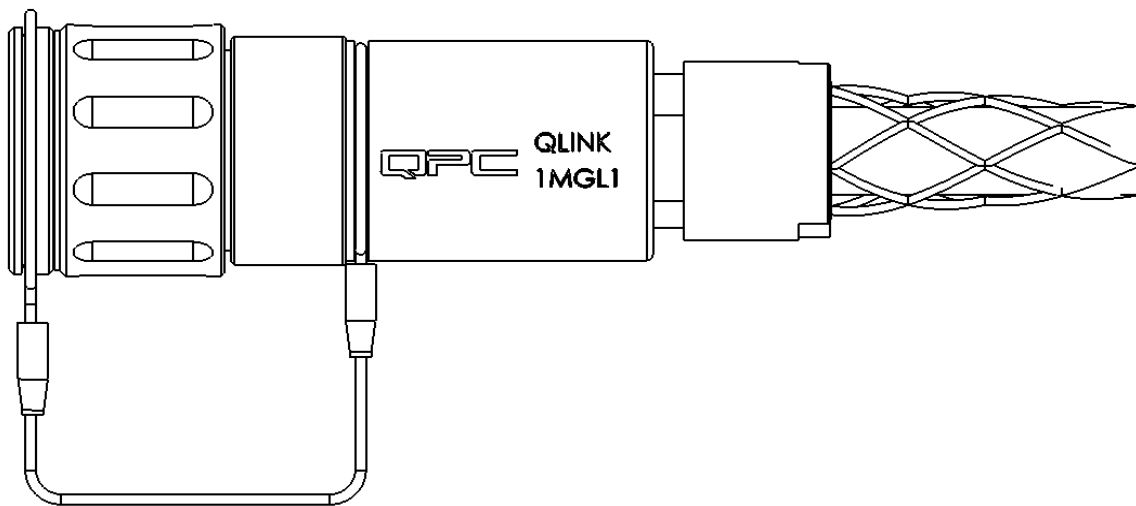


To Torque Backshell, place the Torque Fixture Connector Plate PT-601 or PT-602 with the appropriate mating Torque Fixture installed into the vise PT-591. Attach the Adjustable Crow's Foot Wrench PT-536 or PT-546 onto Dial Torque-Measuring Wrench PT-506. Hand-tighten QLink Plug to Torque Fixture and Torque Backshell Cover according to the values in the above Torque Table. Finally, Torque the Backnut according to the values in the above Torque Table.

*Image with Bend Limiter Assembly*

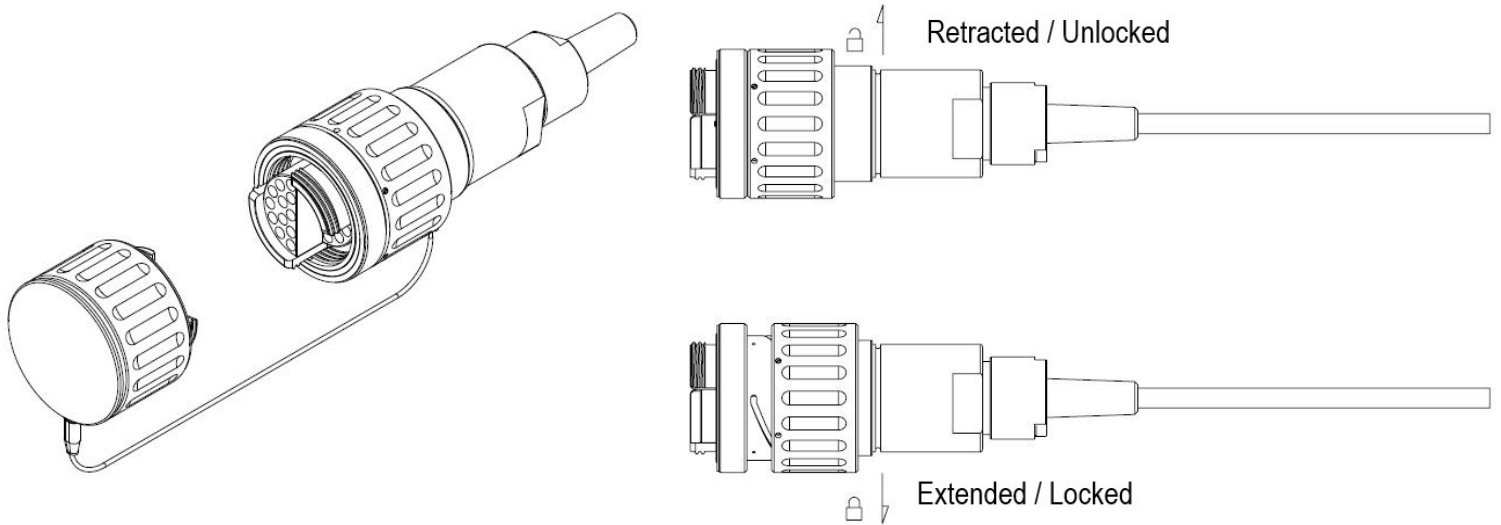


*Image with Cable Grip Assembly*



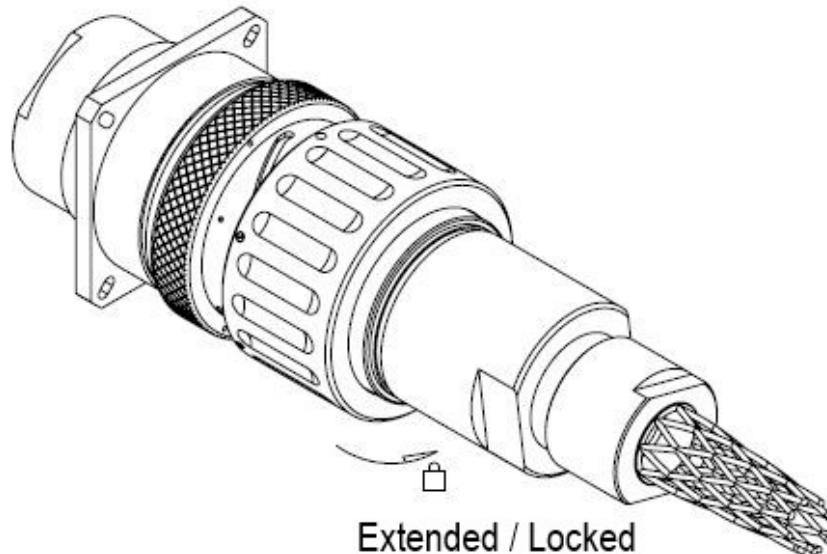
## LOCKING HERMAPHRODITIC

The Locking Hermaphroditic Coupling Ring used with the QLink Locking Hermaphroditic Connector is designed to allow the connector to be de-mated with little effort.



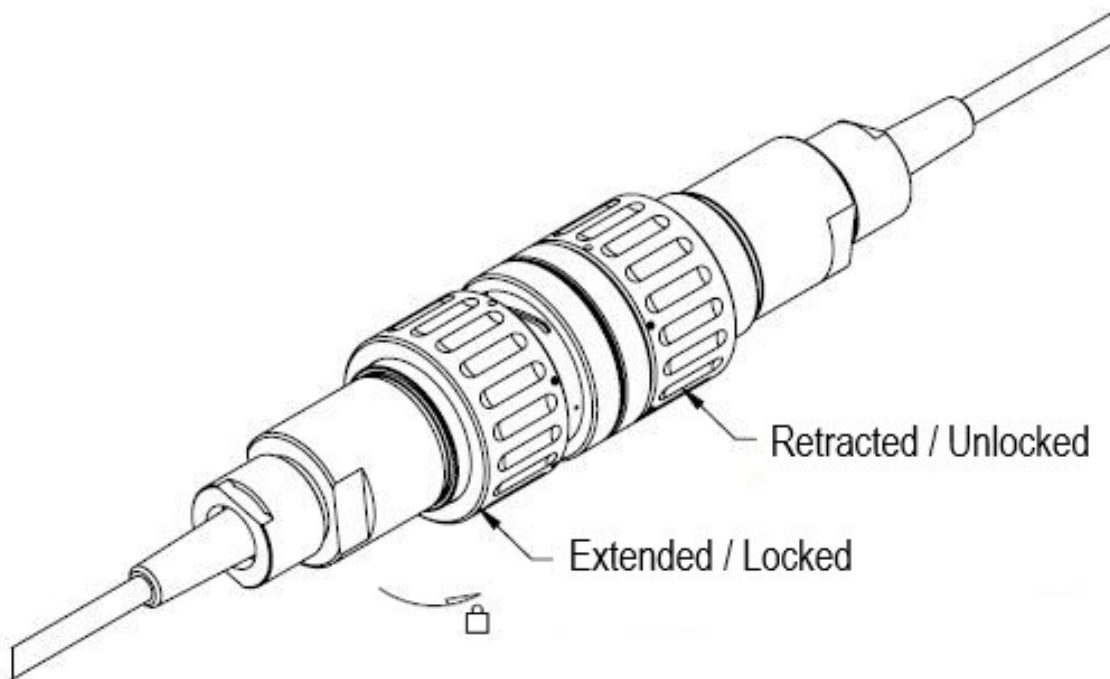
## Operation Plug to Receptacle

When de-mating a Plug to Receptacle Connector Pair, the Locking Hermaphroditic Coupling Ring will automatically extend when turned counterclockwise and rest on the Backshell of the connector. As it is rotated, in the extended / locked state, the threads on the Receptacle will work with the Locking Hermaphroditic Coupling Ring to separate the Pin Termini from the Socket Termini. When the Locking Hermaphroditic Coupling Ring has been fully unscrewed, the connectors will separate easily.



## Operation Plug to Plug

When de-mating a Plug to Plug Connector Pair, the operation is similar to the Plug to Receptacle procedure above, except that one of the Locking Hermaphroditic Coupling Rings must be completely unscrewed and pushed back onto the anti-rotation tabs in its retracted / unlocked state. This ensures that the Locking Hermaphroditic Coupling Ring is completely free from the mating connector's threads allowing the other Locking Hermaphroditic Coupling Ring to work as described above. Once one of the Locking Hermaphroditic Coupling Rings is retracted, the other Locking Hermaphroditic Coupling Ring will automatically extend when turned counterclockwise and rest on the Backshell of the connector. As it is rotated, in the extended / locked state, the threads on the mating Plug will work with the Locking Hermaphroditic Coupling Ring to separate the pin termini from the socket termini. When the Locking Hermaphroditic Coupling Ring has been fully unscrewed, the connectors will separate easily.



# Appendix

---

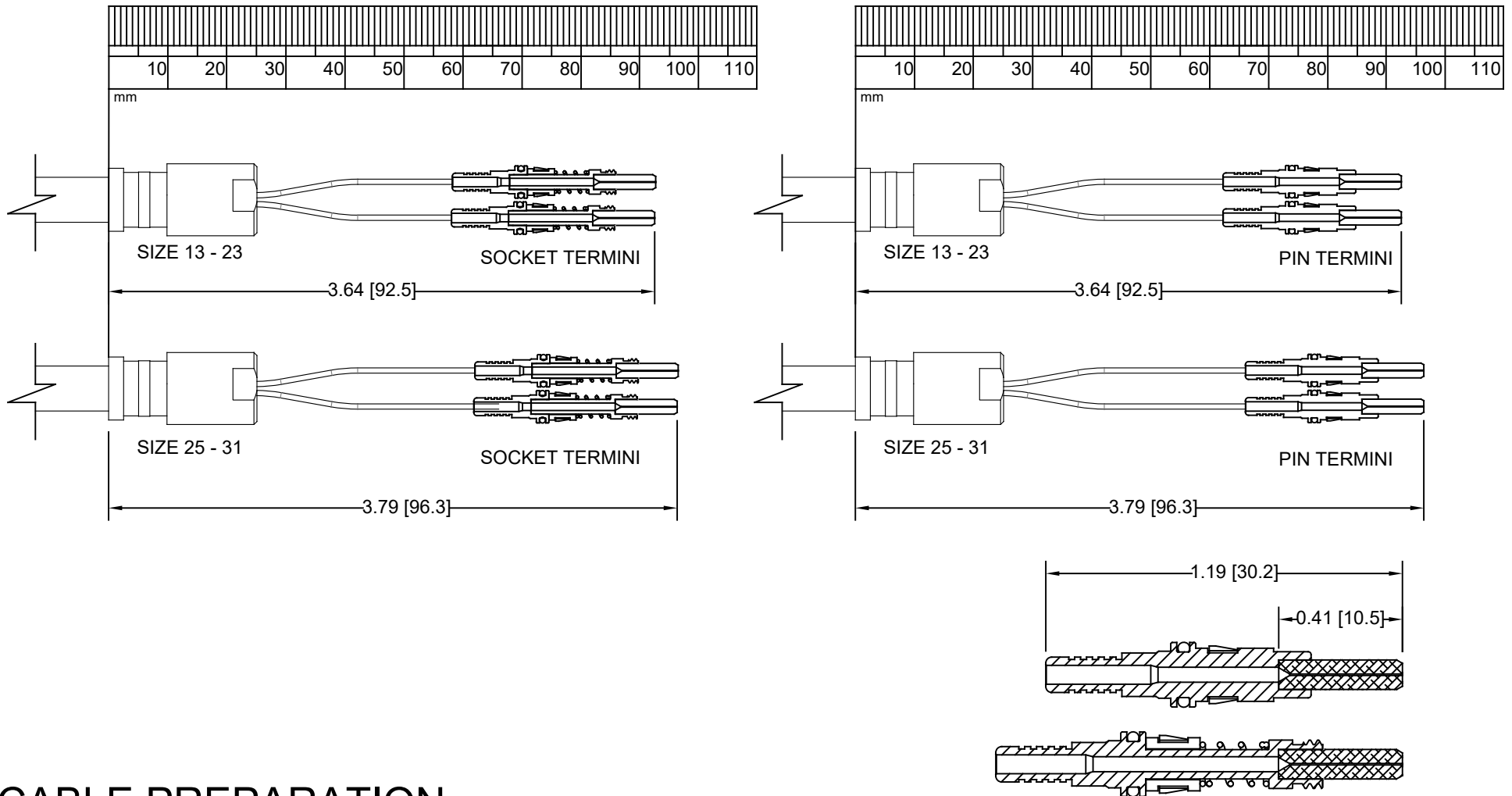
## APPENDIX A: STRIPPING LENGTHS – QLink PLUG ALL SIZES AND CONFIGURATIONS

- D50110 – QLink THREADED AND REVERSE BAYONET PLUG, FIBER OPTIC TERMINI
- D50111 – QLink THREADED AND REVERSE BAYONET PLUG, HYBRID
- D50112 – QLink THREADED AND REVERSE BAYONET PLUG, MT
- D50113 – QLink HERMAPHRODITIC & LOCKING HERMAPHRODITIC PLUG, FIBER OPTIC TERMINI
- D50114 – QLink HERMAPHRODITIC & LOCKING HERMAPHRODITIC PLUG, HYBRID
- D50115 – QLink HERMAPHRODITIC & LOCKING HERMAPHRODITIC PLUG, MT
- D50116 – QLink PUSH PULL PLUG, FIBER OPTIC TERMINI
- D50117 – QLink PUSH PULL PLUG, HYBRID
- D50118 – QLink PUSH PULL PLUG, MT


## APPENDIX B: QPC FIBER OPTIC – QLink CONTACT CRIMP TOOLS / SETTINGS



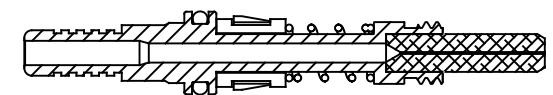
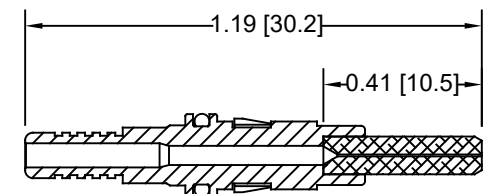
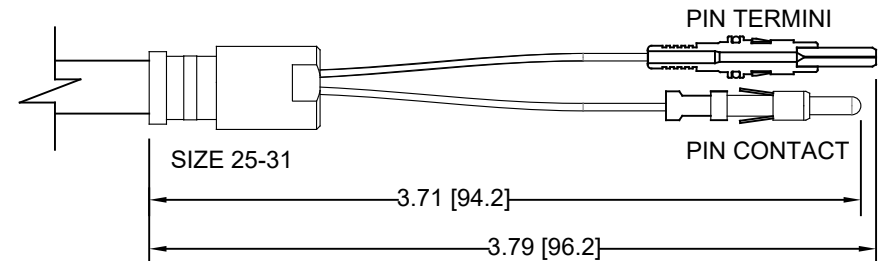
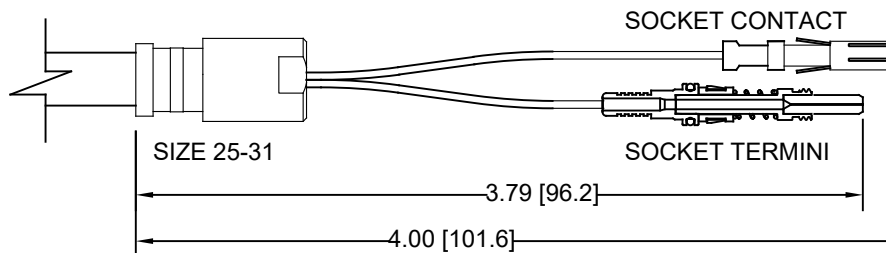
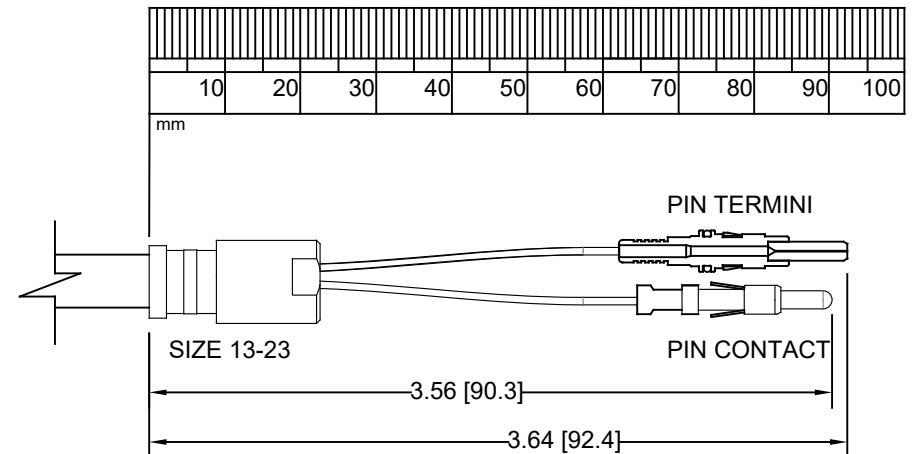
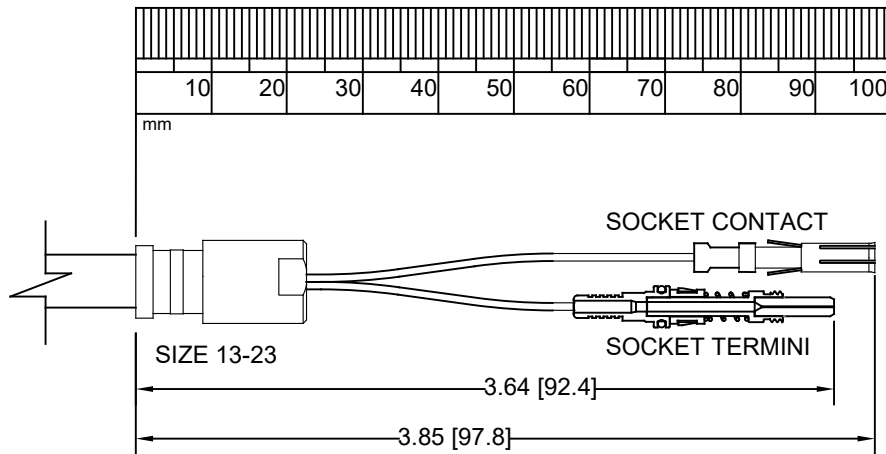
# QLink THREADED AND REVERSE BAYONET PLUG OR RECEPTACLE, FIBER OPTIC TERMINI




## CABLE PREPARATION

 <p><b>QPC</b> ENGINEERED FIBER OPTIC SOLUTIONS</p> <p><b>QPC Fiber Optic, LLC</b></p>	<b>PROPRIETARY AND CONFIDENTIAL</b> THE INFORMATION CONTAINED IN THIS DRAWING IS CONFIDENTIAL AND THE SOLE PROPERTY OF QPC FIBER OPTIC. ANY REPRODUCTION IN PART OR AS A WHOLE OR DISCLOSURE OF CONTENT WITHOUT THE WRITTEN PERMISSION OF QPC FIBER OPTIC IS PROHIBITED.		DOC. NUMBER <b>D50110</b>	REV. <b>0</b>				
	DRAWN <b>CWN</b>	CHECKED 	DIMENSIONS ARE IN INCH[MM].		REV.	DESCRIPTION	DATE	APPROVED
	DATE <b>6/27/19</b>	DATE	SHEET 1 OF 1		REVISIONS			

# QLink THREADED AND REVERSE BAYONET PLUG OR RECEPTACLE, HYBRID

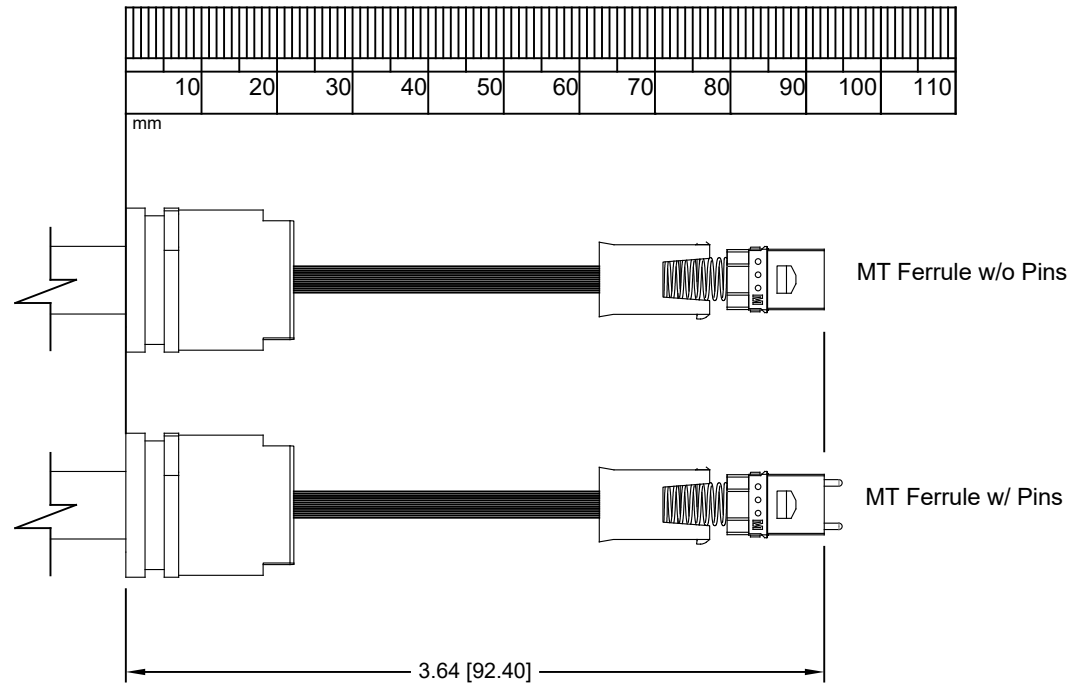


## CABLE PREPARATION

 <b>QPC</b> ENGINEERED FIBER OPTIC SOLUTIONS <b>QPC Fiber Optic, LLC</b>	PROPRIETARY AND CONFIDENTIAL THE INFORMATION CONTAINED IN THIS DRAWING IS CONFIDENTIAL AND THE SOLE PROPERTY OF QPC FIBER OPTIC. ANY REPRODUCTION IN PART OR AS A WHOLE OR DISCLOSURE OF CONTENT WITHOUT THE WRITTEN PERMISSION OF QPC FIBER OPTIC IS PROHIBITED.		DOC. NUMBER <b>D50111</b>	REV. <b>0</b>
	DRAWN <b>CWN</b>	CHECKED 	DIMENSIONS ARE IN INCH[MM].	
	DATE <b>6/27/19</b>	DATE 	SHEET 1 OF 1	
	REV. DESCRIPTION DATE APPROVED			

REV.	DESCRIPTION	DATE	APPROVED
	REVISIONS		

# QLink THREADED AND REVERSE BAYONET PLUG OR RECEPTACLE, MT



## CABLE PREPARATION



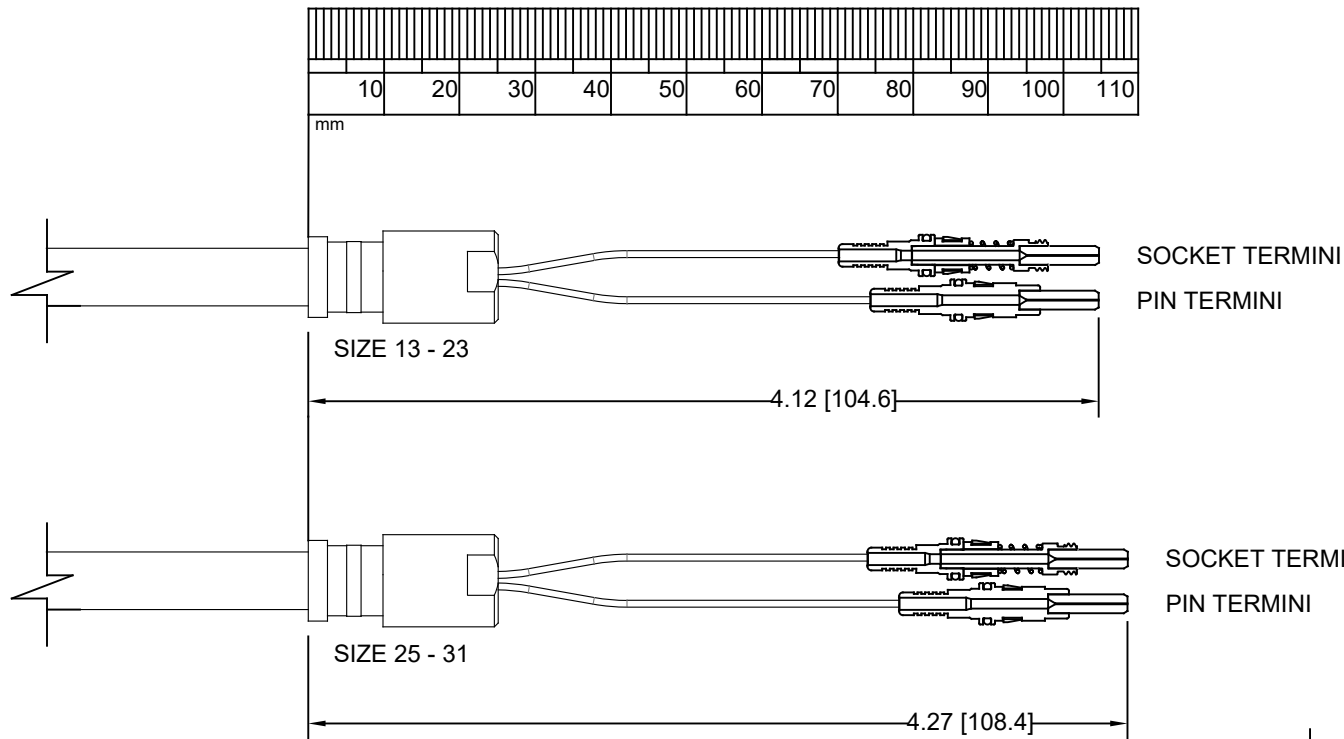
ENGINEERED FIBER OPTIC SOLUTIONS  
QPC Fiber Optic, LLC

**PROPRIETARY AND CONFIDENTIAL**  
THE INFORMATION CONTAINED IN THIS DRAWING IS CONFIDENTIAL AND THE SOLE PROPERTY OF QPC FIBER OPTIC. ANY REPRODUCTION IN PART OR AS A WHOLE OR DISCLOSURE OF CONTENT WITHOUT THE WRITTEN PERMISSION OF QPC FIBER OPTIC IS PROHIBITED.

DOC. NUMBER		REV.	
D50112		0	
DRAWN	CHECKED	DIMENSIONS ARE IN INCH[MM].	
CN			
DATE	DATE	SHEET 1 OF 1	
6/27/19			

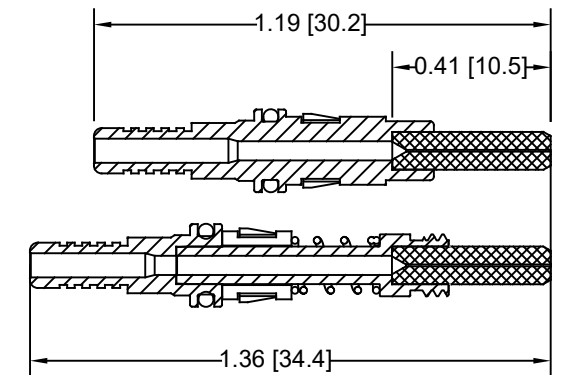
REV.	DESCRIPTION	DATE	APPROVED
REVISIONS			

# QLink HERMAPHRODITIC AND LOCKING HERMAPHRODITIC PLUG OR RECEPTACLE, FIBER OPTIC TERMINI



SOCKET TERMINI  
PIN TERMINI

SOCKET TERMINI  
PIN TERMINI



## CABLE PREPARATION

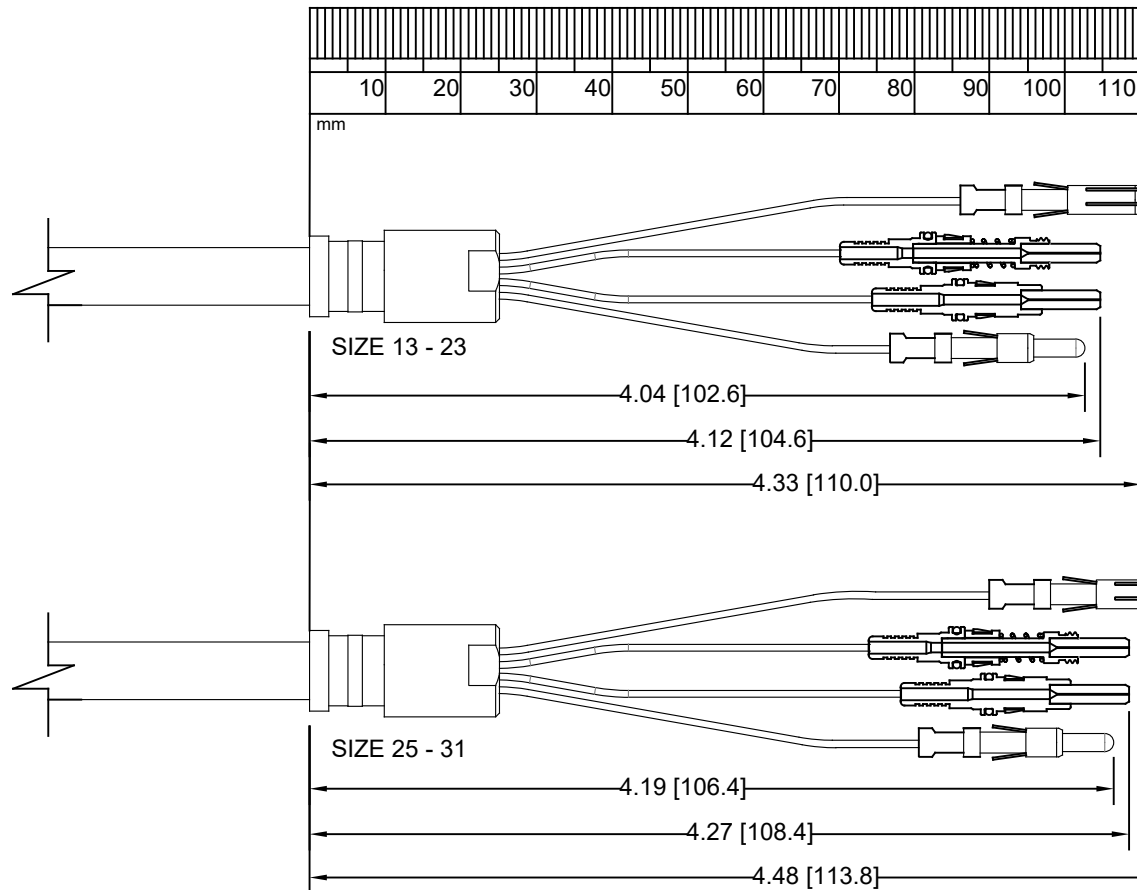


**PROPRIETARY AND CONFIDENTIAL**  
THE INFORMATION CONTAINED IN THIS DRAWING IS CONFIDENTIAL AND THE SOLE PROPERTY OF QPC FIBER OPTIC. ANY REPRODUCTION IN PART OR AS A WHOLE OR DISCLOSURE OF CONTENT WITHOUT THE WRITTEN PERMISSION OF QPC FIBER OPTIC IS PROHIBITED.

DOC. NUMBER		D50113		REV.	0
DRAWN	CHECKED	DIMENSIONS ARE IN INCH[MM].			
CWN					
DATE	DATE	SHEET 1 OF 1			
6/27/19					

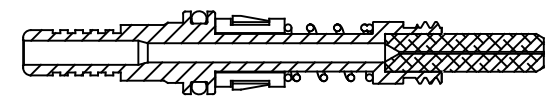
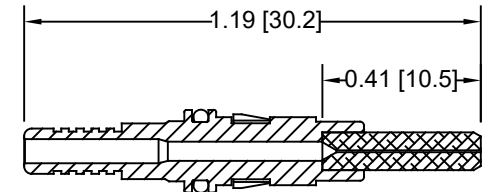
REV.	DESCRIPTION	DATE	APPROVED
	REVISIONS		

# QLink HERMAPHRODITIC AND LOCKING HERMAPHRODITIC PLUG OR RECEPTACLE, HYBRID



SOCKET CONTACT  
SOCKET TERMINI  
PIN TERMINI  
PIN CONTACT

SOCKET CONTACT  
SOCKET TERMINI  
PIN TERMINI  
PIN CONTACT



## CABLE PREPARATION

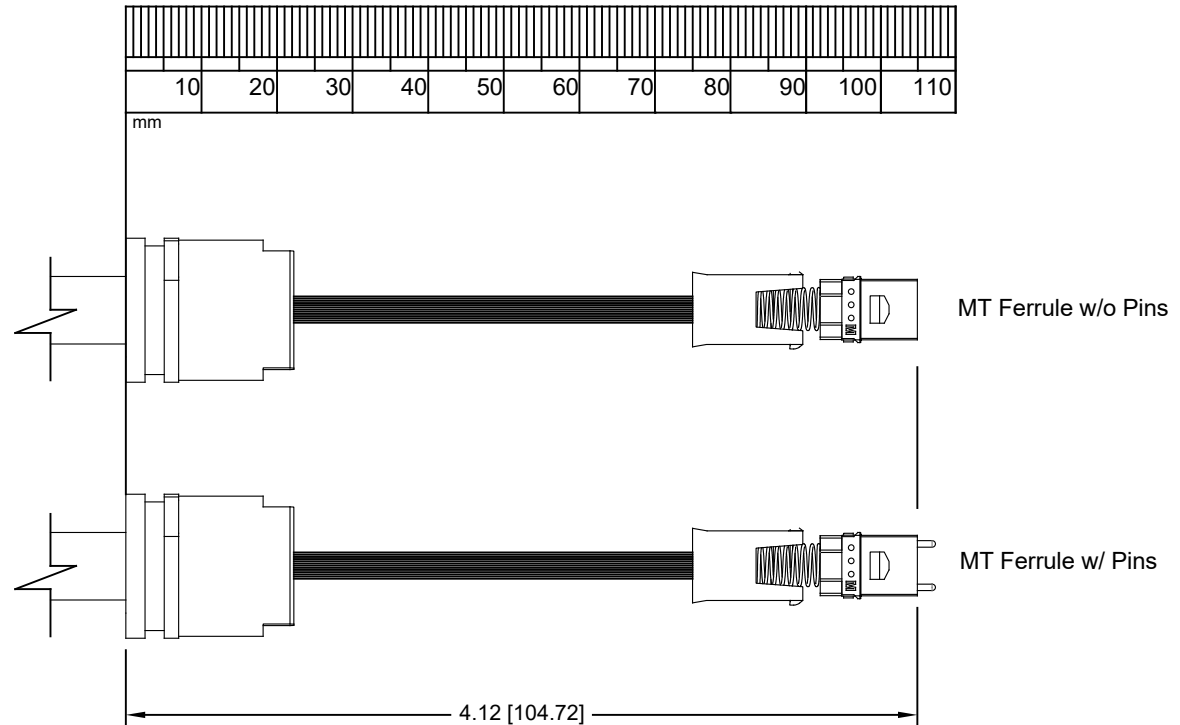


PROPRIETARY AND CONFIDENTIAL  
THE INFORMATION CONTAINED IN  
THIS DRAWING IS CONFIDENTIAL AND  
THE SOLE PROPERTY OF QPC FIBER  
OPTIC. ANY REPRODUCTION IN PART  
OR AS A WHOLE OR DISCLOSURE OF  
CONTENT WITHOUT THE WRITTEN  
PERMISSION OF QPC FIBER OPTIC IS  
PROHIBITED.

DOC. NUMBER		REV.	
D50114		0	
DRAWN	CHECKED	DIMENSIONS ARE IN INCH[MM].	
CWN			
DATE	DATE	REV.	
6/27/19			
SHEET 1 OF 1			

REV.	DESCRIPTION	DATE	APPROVED
REVISIONS			

# QLink HERMAPHRODITIC AND LOCKING HERMAPHRODITIC PLUG OR RECEPTACLE, MT



## CABLE PREPARATION



ENGINEERED FIBER OPTIC SOLUTIONS

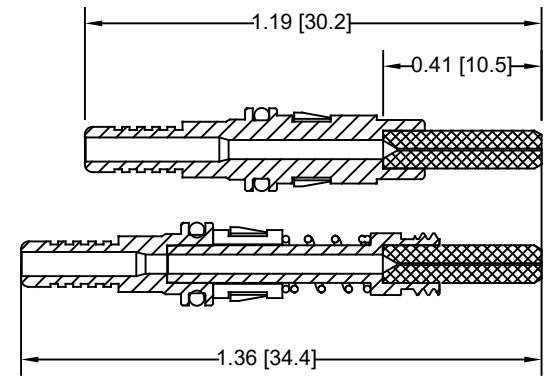
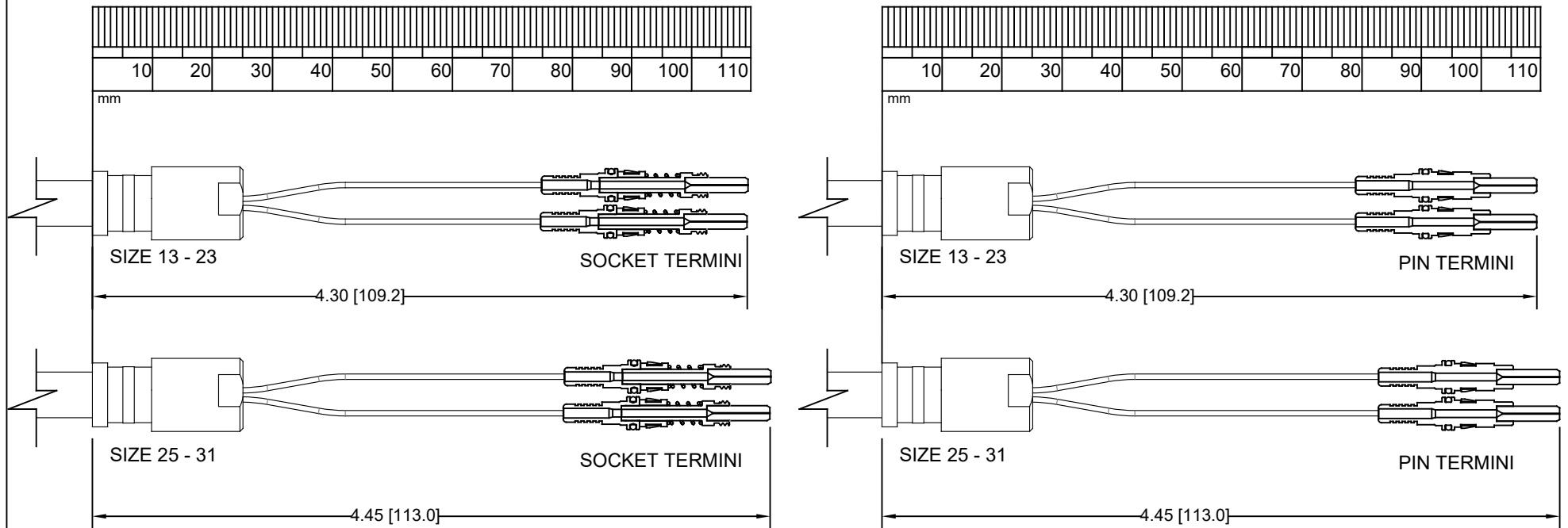
QPC Fiber Optic, LLC

**PROPRIETARY AND CONFIDENTIAL**  
THE INFORMATION CONTAINED IN THIS DRAWING IS CONFIDENTIAL AND THE SOLE PROPERTY OF QPC FIBER OPTIC. ANY REPRODUCTION IN PART OR AS A WHOLE OR DISCLOSURE OF CONTENT WITHOUT THE WRITTEN PERMISSION OF QPC FIBER OPTIC IS PROHIBITED.

DOC. NUMBER		REV.	
D50115		0	
DRAWN	CHECKED	DIMENSIONS ARE IN INCH[MM].	
CN			
DATE	DATE	SHEET 1 OF 1	
06/27/19			

REV.	DESCRIPTION	DATE	APPROVED
REVISIONS			

# QLink PUSH PULL PLUG OR RECEPTACLE, FIBER OPTIC TERMINI



## CABLE PREPARATION



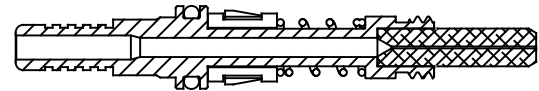
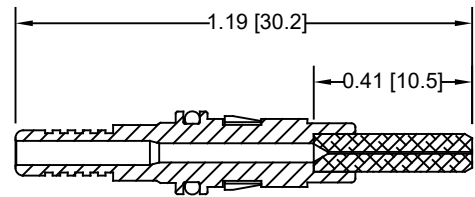
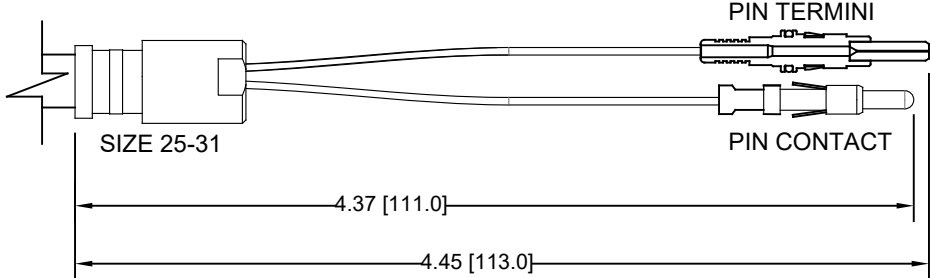
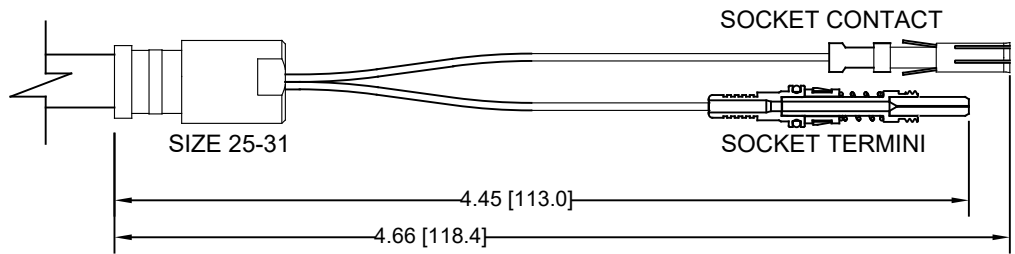
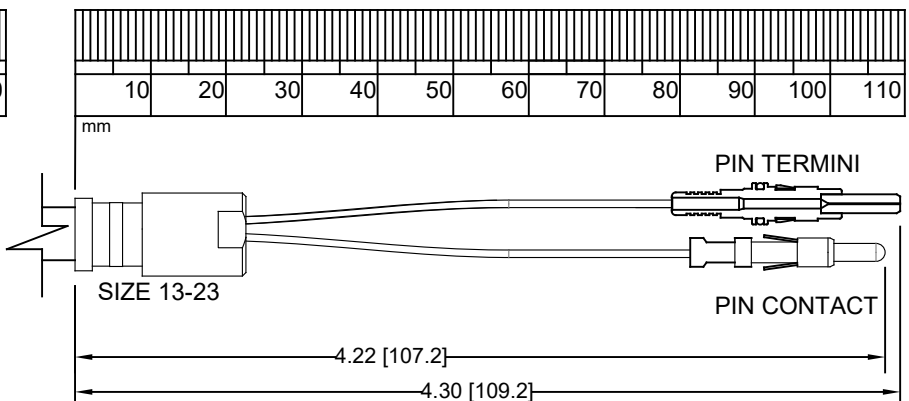
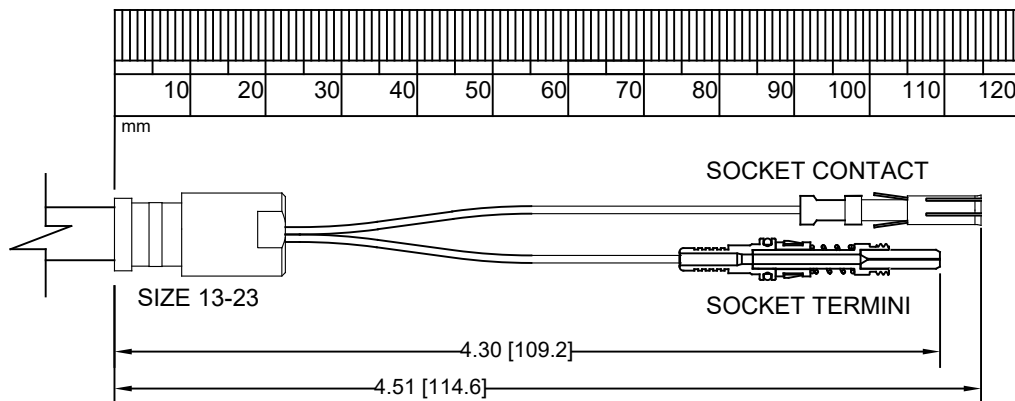
**PROPRIETARY AND CONFIDENTIAL**  
 THE INFORMATION CONTAINED IN THIS DRAWING IS CONFIDENTIAL AND THE SOLE PROPERTY OF QPC FIBER OPTIC. ANY REPRODUCTION IN PART OR AS A WHOLE OR DISCLOSURE OF CONTENT WITHOUT THE WRITTEN PERMISSION OF QPC FIBER OPTIC IS PROHIBITED.

DOC. NUMBER		REV.	
D50116		0	
DRAWN	CHECKED	DIMENSIONS ARE IN INCH[MM].	
CN			
DATE	DATE	SHEET 1 OF 1	
06/27/19			

REV.	DESCRIPTION	DATE	APPROVED
REVISIONS			



# QLink PUSH PULL PLUG OR RECEPTACLE, HYBRID



## CABLE PREPARATION

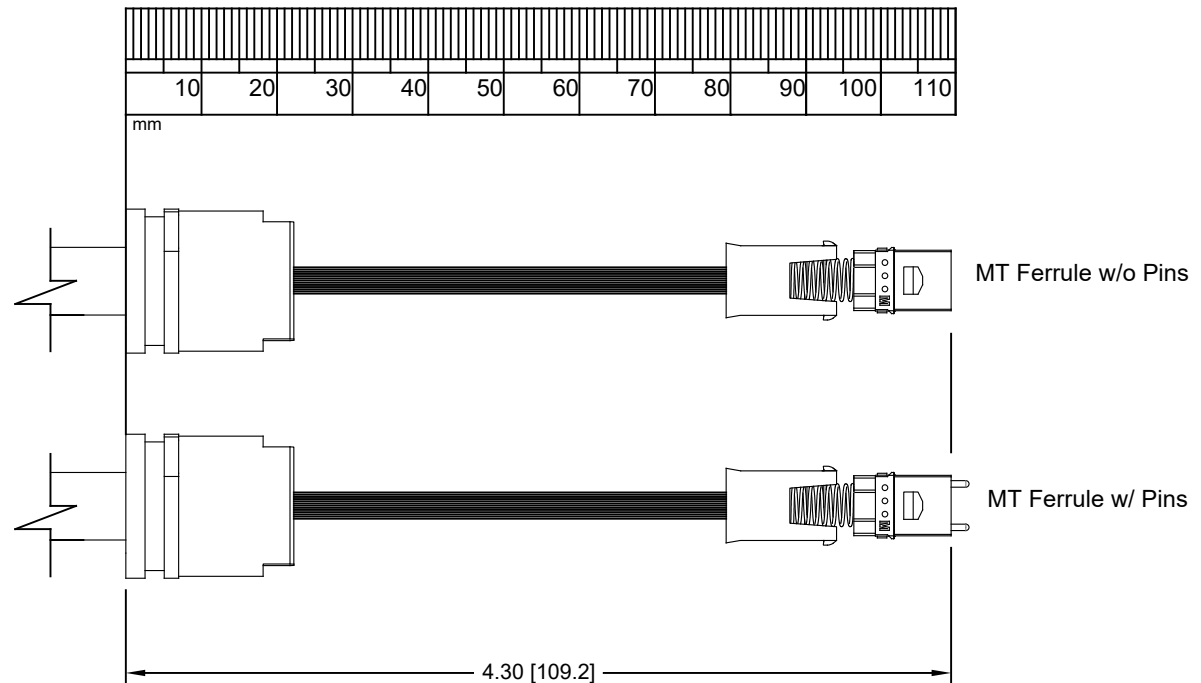


**PROPRIETARY AND CONFIDENTIAL**  
 THE INFORMATION CONTAINED IN THIS DRAWING IS CONFIDENTIAL AND THE SOLE PROPERTY OF QPC FIBER OPTIC. ANY REPRODUCTION IN PART OR AS A WHOLE OR DISCLOSURE OF CONTENT WITHOUT THE WRITTEN PERMISSION OF QPC FIBER OPTIC IS PROHIBITED.

DOC. NUMBER		REV.	
D50117		0	
DRAWN	CHECKED	DIMENSIONS ARE IN INCH[MM].	
CN			
DATE	DATE	SHEET 1 OF 1	
06/27/19			

REV.	DESCRIPTION	DATE	APPROVED
REVISIONS			

# QLink PUSH PULL PLUG OR RECEPTACLE, MT



## CABLE PREPARATION



ENGINEERED FIBER OPTIC SOLUTIONS

QPC Fiber Optic, LLC

**PROPRIETARY AND CONFIDENTIAL**  
THE INFORMATION CONTAINED IN THIS DRAWING IS CONFIDENTIAL AND THE SOLE PROPERTY OF QPC FIBER OPTIC. ANY REPRODUCTION IN PART OR AS A WHOLE OR DISCLOSURE OF CONTENT WITHOUT THE WRITTEN PERMISSION OF QPC FIBER OPTIC IS PROHIBITED.

DOC. NUMBER		REV.	
D50118		0	
DRAWN	CHECKED	DIMENSIONS ARE IN INCH[MM].	
CN			
DATE	DATE	SHEET 1 OF 1	
06/27/19			

REV.	DESCRIPTION	DATE	APPROVED
REVISIONS			

## APPENDIX B - QPC Fiber Optic - QLink Contact Crimp Tools / Settings

QPC P/N	Contact Size	Pin / Socket	Wire Size Range (AWG)	Crimp Tool	Turret / Positioner	Wire Size (AWG)	Turret Color Setting	Crimp Selector Number
QLINK-CTC-1624P	16	Pin	24-26	PT-560	PT-562	26	Blue	2
						24	Blue	3
QLINK-CTC-1624S	16	Socket	24-26	PT-560	PT-562	26	Green	2
						24	Green	3
QLINK-CTC-1620P	16	Pin	20-22	PT-560	PT-562	22	Blue	3
						20	Blue	4
QLINK-CTC-1620S	16	Socket	20-22	PT-560	PT-562	22	Green	3
						20	Green	4
QLINK-CTC-1616P	16	Pin	16-20	PT-560	PT-562	20	Blue	4
						18	Blue	5
						16	Blue	5
QLINK-CTC-1616S	16	Socket	16-20	PT-560	PT-562	20	Green	4
						18	Green	5
						16	Green	5
QLINK-CTC-1614P	16	Pin	14-16	PT-560	PT-562	16	Blue	6
						14	Blue	7
QLINK-CTC-1614S	16	Socket	14-16	PT-560	PT-562	16	Green	5
						14	Green	6
QLINK-CTC-1214P	12	Pin	14	PT-561	PT-563	14	N/A	3
QLINK-CTC-1214S	12	Socket	14	PT-561	PT-563	14	N/A	3
QLINK-CTC-1212P	12	Pin	12	PT-561	PT-563	12	N/A	3
QLINK-CTC-1212S	12	Socket	12	PT-561	PT-563	12	N/A	3
QLINK-CTC-0812P	8	Pin	12	PT-561	PT-564	12	N/A	4
QLINK-CTC-0812S	8	Socket	12	PT-561	PT-564	12	N/A	4
QLINK-CTC-0810P	8	Pin	10	PT-561	PT-564	10	N/A	5
QLINK-CTC-0810S	8	Socket	10	PT-561	PT-564	10	N/A	5
QLINK-CTC-0808P	8	Pin	8	PT-561	PT-564	8	N/A	6
QLINK-CTC-0808S	8	Socket	8	PT-561	PT-564	8	N/A	6

Note: Wire size may differ slightly by wire type / manufacturer. Crimp Selector setting may need to be adjusted (up or down) accordingly to achieve proper retention.